



TECH-TC SERIES CONTROL VALVES

FILTERS, SOFTENERS, CONDITIONERS



1 INCH TECH-TC SERIES CONTROL VALVE MODEL: WS1TC

1.25 INCH TECH-TC SERIES CONTROL VALVE MODEL: WS1.25TC

Quick Guide

Arrow will point to Regen if a regeneration is expected "Tonight."

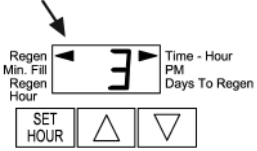

MANUAL REGENERATION

NOTE: For softeners, if brine tank does not contain salt, fill with salt and wait at least 2 hours before regeneration. If you need to initiate a manual regeneration, either immediately, or tonight at the preprogrammed time (typically 2 a.m.), complete the following steps.

For Immediate Regeneration: Press and hold UP and DOWN simultaneously until valve motor starts (typically 3 seconds).

For Regeneration Tonight: Press and release UP and DOWN simultaneously (notice that arrow points to Regen).

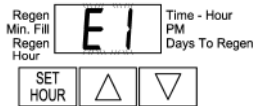

ERRORS

If the display shows "E1," "E2" or "E3" (for error), call a service technician.

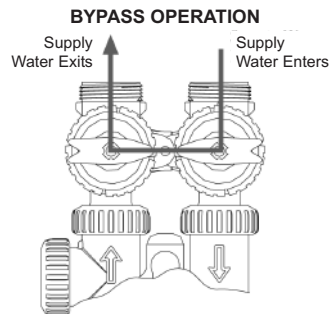
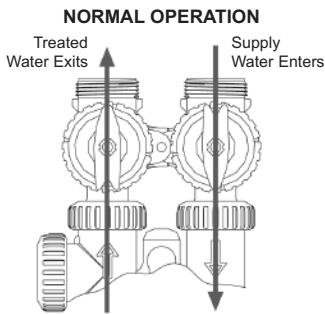

TO SHUT OFF WATER

To shut off water to the system, position the arrow handles as shown in the bypass operation drawing to the left. If your valve doesn't look like the drawing, contact your service technician for instructions on how to shut off water.

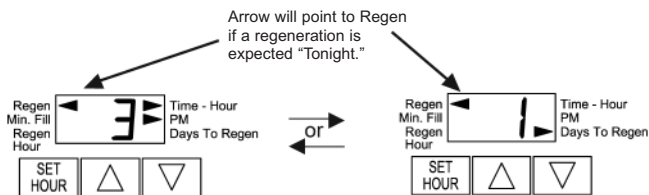

GENERAL OPERATION

When the system is operating one of two displays will be shown: time of day or days until the next regeneration. Pressing UP or DOWN will toggle between the two choices.

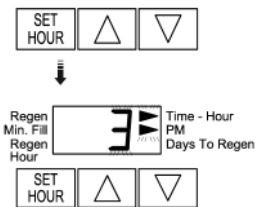

TO SET TIME OF DAY

In the event of a power outage, time of day needs to be reset. All other information will be stored in memory no matter how long the power outage. Please complete the following steps. To access this mode, press SET HOUR.

1. Accessed by pressing SET HOUR.
2. Adjust to the nearest hour using UP or DOWN. An arrow points to PM during p.m. hours.
3. Press SET HOUR to complete and return to normal operation.

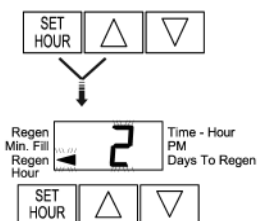

TO SET TIME OF REGENERATION

For initial set-up or to make adjustments, complete the following steps. Access this mode by pressing SET HOUR and UP simultaneously for 3 seconds.

1. Accessed by pressing SET HOUR and UP simultaneously for 3 seconds.
2. Adjust time of regeneration hour using UP or DOWN. An arrow points to PM during p.m. hours.
3. Simultaneously press SET HOUR and DOWN to return to normal operation.

Table of Contents

- 4. Control Valve Function and Cycles of Operation**
- 4. Table 1. Regeneration Cycles and Times for Different Programs
- 5. General Instructions**
- 6. OEM System Setup Programming**
- 6. Step 1-SS. Access OEM System Setup Mode
- 6. Step 2-SS. Select a Program Option
- 6. Step 3-SS. Program Minutes of Fill
- 7. Step 4-SS. Select Regeneration Option
- 7. Step 5-SS. Select 50 Hz or 60 Hz Option
- 7. Step 6-SS. Select Differential Pressure Switch Options
- 8. Installer Displays & Settings Programming**
- 8. 1-99 Days Between Regeneration Option
- 8. Step 1-NA. Access Installer Displays & Settings Mode
- 8. Step 2-NA. Program Regeneration Time
- 8. Step 3-NA. Program Days Between Regenerations
- 8. 7 Day (Days of the Week) Regeneration Option
- 8. Step 1-NB. Access Installer Displays & Settings Mode
- 8. Step 2-NB Program Regeneration Time
- 8. Step 3-NB Program Current Day of the Week
- 8. Step 4-NB Program Sunday Regeneration
- 8. Step 5-NB Program Monday Regeneration
- 9. Step 6-NB Program Tuesday Regeneration
- 9. Step 7-NB Program Wednesday Regeneration
- 9. Step 8-NB Program Thursday Regeneration
- 9. Step 9-NB Program Friday Regeneration
- 9. Step 10-NB Program Saturday Regeneration
- 9. User Displays & Settings Programming**
- 9. General Operation
- 9. Regeneration Mode
- 10. Manual Regeneration
- 10. Set Time of Day
- 10. Power Loss
- 10. Error Message
- 11. Drawings and Part Numbers**
- 12. Front Cover and Drive Assembly
- 13. WS1TC Drive Cap Assembly, Downflow Piston, Regenerant Piston, and Spacer Stack Assembly
- 14. WS1.25TC Drive Cap Assembly, Downflow Piston, Regenerant Piston, and Spacer Stack Assembly
- 15. WS1 & WS1.25 Identification

Control Valve Function and Cycles of Operation

This glass filled Noryl¹ (or equivalent) fully automatic control valve is designed as the primary control center to direct and regulate all cycles of a downflow regeneration water softener or filter.

The time clock control valve can be set to perform downflow regeneration or simply backwash. The time clock control valve has two calendar options for regeneration frequency:

1. an option where the user can choose the number of days (1-99) between each regeneration; and
2. a seven-day option where the user can choose which day(s) of the week a regeneration should occur.

The control valve is compatible with a variety of regenerants and resin cleaners. The control valve is capable of routing the flow of water in the necessary paths to regenerate or backwash water treatment systems. The injector regulates the flow of brine or other regenerants. The control valve regulates the flow rates for backwashing, rinsing, and the replenishing of treated water into a regenerant tank, when applicable.

The control valve uses no traditional fasteners (e.g. screws); instead clips, threaded caps and nuts, and snap type latches are used. Caps and nuts only need to be firmly hand tightened because radial seals are used. Tools required to service the valve include one small blade screwdriver, one large blade screwdriver, pliers, and a pair of hands. A plastic wrench is available which eliminates the need for screwdrivers and pliers. Disassembly for servicing takes much less time than comparable products currently on the market. Control valve installation is made easy because the distributor tube can be cut 1/2 inch above to 1/2 inch below the top of tank thread. The distributor tube is held in place by an o-ring seal and the control valve also has a bayonet lock feature for upper distributor baskets.

The AC adapter power pack comes with a 15 foot power cord and is designed for use with the control valve. The AC adapter power pack is for dry location use only. If the power goes out, only the time of day needs to be reset. All other values are permanently stored in the nonvolatile memory.

Table 1 shows the time for the backwash, regenerative, and rinse cycles for the ten available programming options. Six different programs are available for a softener, one for a regenerative filter, and three programs for backwash only filters. When the control valve is used as a:

1. softener, one or two backwashes occur and refill always occurs after the rinse cycle (P0 through P5);
2. regenerative filter, one backwash occurs and refill always occurs after the rinse cycle (P6); and
3. backwashing filter, one backwash occurs (P7 through P9).

Table 1
Regeneration Cycles and Times for Different Programs

PROGRAM	ALL TIME IN MINUTES				
	C1 1ST BACKWASH	C2 REGENERATE	C3 2ND BACKWASH	C4 RINSE	C5 FILL
P0	3	50	3	3	1-99
P1	8	50	8	4	1-99
P2	8	70	10	6	1-99
P3	12	70	12	8	1-99
P4	10	50	Skipped	8	1-99
P5	4	50	Skipped	4	1-99
P6	12	6	Skipped	12	1-99
P7	6	Skipped	Skipped	4	Skipped
P8	10	Skipped	Skipped	6	Skipped
P9	14	Skipped	Skipped	8	Skipped

NOTE: During regeneration the display will show C1, C2, etc. If the cycle is skipped, that cycle number will not be displayed.

1. Noryl is a trademark of General Electric.

The user can initiate manual regeneration. The user has the option to request the manual regeneration at the delayed regeneration time or to have the regeneration occur immediately. Simultaneously press the UP + DOWN buttons to start a regeneration at the next delayed regeneration time. If a regeneration is to occur today an arrow will point to regeneration. For immediate regeneration, simultaneously press and hold the UP + DOWN buttons for three seconds.

When in regeneration, step through the different regeneration cycles by simultaneously pressing the UP + DOWN buttons.

General Instructions

The control valve offers multiple procedures that allow the valve to be modified to suit the needs of the installation. These procedures are:

- OEM System Setup
- Installer Displays & Settings (either 1-99 Days Between Regeneration option or 7-Day option)
- User Displays

These procedures can be accessed in any order. Details on each of the procedures are provided below and on the following pages.

When in operation, normal user displays show the time of day or days remaining before regeneration. When stepping through a procedure, if no buttons are pressed within five minutes, the display returns to a normal user display. Any changes made prior to the five minute time out are incorporated.

To quickly exit Installer Displays & Settings or OEM System Setup, simultaneously press SET HOUR + DOWN. Any changes made prior to the exit are incorporated.

To reinitialize the control valve, check to make sure the valve is in the User Display. Then simultaneously press SET HOUR + DOWN or unplug power source plug (black wire) on the circuit board, and plug back in.

OEM System Setup

STEP 1-SS

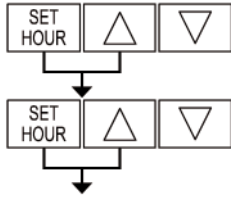

STEP 1-SS – From normal mode, press SET HOUR + UP buttons simultaneously for 3 seconds and release.

Then (repeat) press SET HOUR + UP buttons simultaneously for 3 seconds and release.

STEP 2-SS

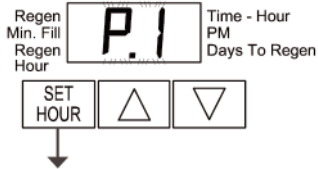

STEP 2-SS – Choose the desired program by pressing the UP or DOWN buttons. (See Table below for Program Parameters)

Prior to selecting a program, verify the correct valve body, main piston, regenerant piston, and stack are being used, and that the injector or injector plug(s) are in the correct locations.

Press SET HOUR button to go to Step 3-SS.

PROGRAM	ALL TIME IN MINUTES				
	C1 1ST BACKWASH	C2 REGENERATE	C3 2ND BACKWASH	C4 RINSE	C5 FILL
P0	3	50	3	3	1-99
P1	8	50	8	4	1-99
P2	8	70	10	6	1-99
P3	12	70	12	8	1-99
P4	10	50	Skipped	8	1-99
P5	4	50	Skipped	4	1-99
P6	12	6	Skipped	12	1-99
P7	6	Skipped	Skipped	4	Skipped
P8	10	Skipped	Skipped	6	Skipped
P9	14	Skipped	Skipped	8	Skipped

NOTE: During regeneration the display will show C1, C2, etc. If the cycle is skipped, that cycle number will not be displayed.

STEP 3-SS

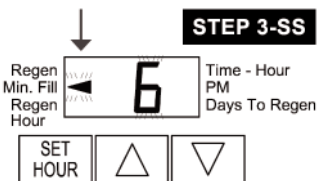

STEP 3-SS – If program P0 through P6 was selected, enter in the minutes of fill using the UP or DOWN buttons. The allowable values vary from a low of 1 to a high of 99.

If program P7, P8, or P9 was selected, dashes will appear for minutes of fill.

Press SET HOUR button to go to Step 4-SS.

Note: For each minute of fill 0.5 gallons of water is added to the solution tank. With salt (sodium chloride) this equates to approximately 1½ pounds of salt per minute of fill.

STEP 4-SS

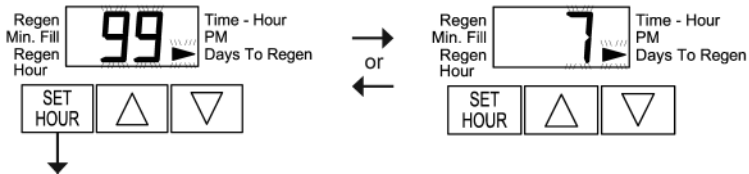

STEP 4-SS — Use UP or DOWN buttons to switch between:

- 1-99 Days Between Regen; or
- 7-Day.

Press SET HOUR button to go to Step 5-SS.

STEP 5-SS

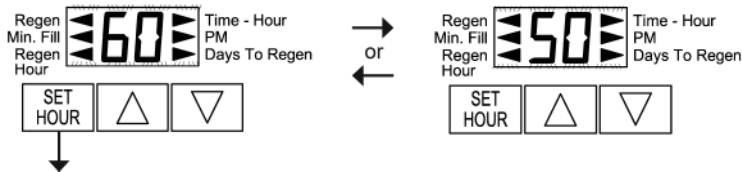

STEP 5-SS — Use UP or DOWN buttons to switch between 60 Hz or 50 Hz option.

Press SET HOUR button to go to Step 6-SS.

STEP 6-SS

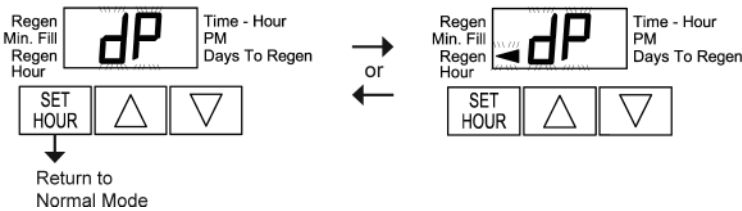

STEP 6-SS — If a differential pressure switch is installed and actuated:

- a regeneration will occur immediately if no arrow points at Regen Hour; or
- a regeneration will occur at the delayed regeneration hour if an arrow points at Regen Hour.

Use UP or DOWN buttons to switch between the two choices. If a differential switch is not installed the settings in this display are ignored.

Press SET HOUR to exit OEM system setup.

NOTE: A regeneration will be initiated or scheduled after the control has received a signal for two minutes.



- A. Differential pressure switch connection
- B. Motor wire connection
- C. AC adapter wire connection

Installer Displays & Settings

1-99 Days Between Regeneration Option

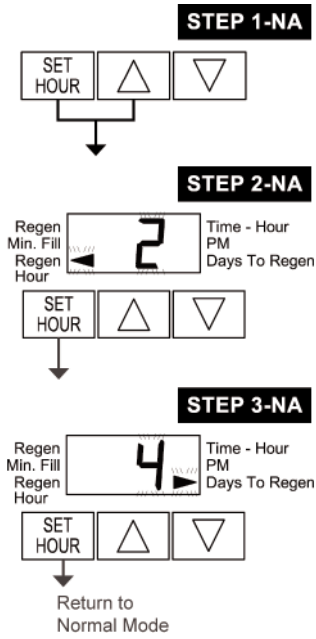

STEP 1-NA – From normal mode, press SET HOUR + UP buttons simultaneously for 3 seconds and release.

STEP 2-NA – *Regeneration Time*: Set the clock to the hour the regeneration should occur by using the UP or DOWN buttons. An arrow points to PM after 12.

Press SET HOUR to go to STEP 3-NA.

STEP 3-NA – *Days To Regen*: Set the number of days between regenerations. The allowable range is 1 to 99.

Press SET HOUR to exit Installer Displays & Settings.

7 Day (Days of the Week) Option

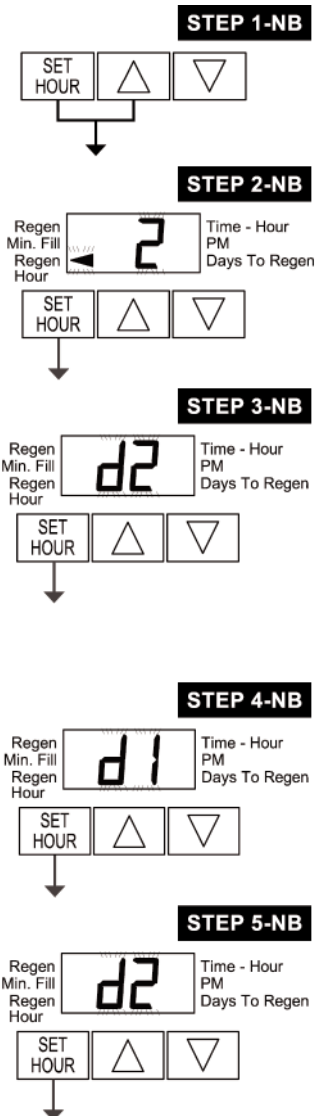

STEP 1-NB – From normal mode, press SET HOUR + UP buttons simultaneously for 3 seconds and release.

STEP 2-NB – *Regeneration Time*: Set the clock to the hour the regeneration should occur by using the UP or DOWN buttons. An arrow points to PM after 12.

Press SET HOUR to go to STEP 3-NB.

STEP 3-NB – *Current Day of Week*: Set the current day of the week by using the UP or DOWN buttons (See list of codes below).

d1 = Sunday; d2 = Monday; d3 = Tuesday; d4 = Wednesday;
 d5 = Thursday; d6 = Friday; d7 = Saturday

Press SET HOUR to go to STEP 4-NB.

STEP 4-NB – *Sunday Regeneration*: To regenerate on Sunday use the UP or DOWN button until the arrow points to Regen. If the arrow does not point to Regen a regeneration will not occur on Sunday.

Press SET HOUR to go to STEP 5-NB.

STEP 5-NB – *Monday Regeneration*: To regenerate on Monday use the UP or DOWN button until the arrow points to Regen. If the arrow does not point to Regen a regeneration will not occur on Monday.

Press SET HOUR to go to STEP 6-NB.

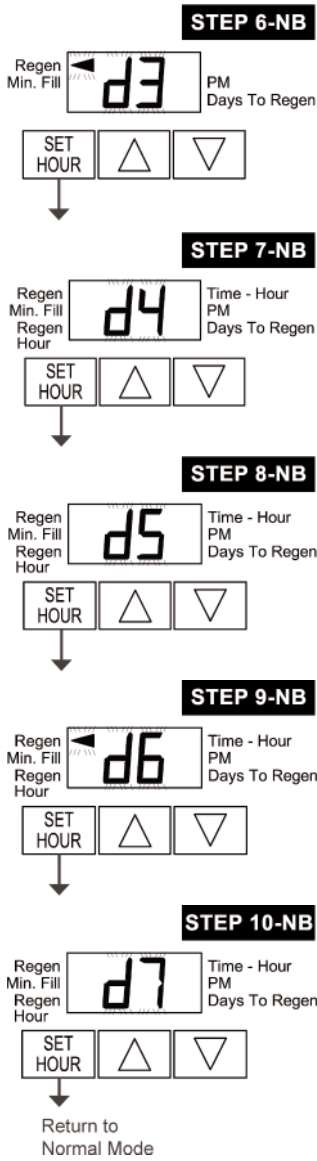

STEP 6-NB – Tuesday Regeneration: To regenerate on Tuesday use the UP or DOWN button until the arrow points to Regen. If the arrow does not point to Regen a regeneration will not occur on Tuesday.

Press SET HOUR to go to STEP 7-NB.

STEP 7-NB – Wednesday Regeneration: To regenerate on Wednesday use the UP or DOWN button until the arrow points to Regen. If the arrow does not point to Regen a regeneration will not occur on Wednesday.

Press SET HOUR to go to STEP 8-NB.

STEP 8-NB – Thursday Regeneration: To regenerate on Thursday use the UP or DOWN button until the arrow points to Regen. If the arrow does not point to Regen a regeneration will not occur on Thursday.

Press SET HOUR to go to STEP 9-NB.

STEP 9-NB – Friday Regeneration: To regenerate on Friday use the UP or DOWN button until the arrow points to Regen. If the arrow does not point to Regen a regeneration will not occur on Friday.

Press SET HOUR to go to STEP 10-NB.

STEP 10-NB – Saturday Regeneration: To regenerate on Saturday use the UP or DOWN button until the arrow points to Regen. If the arrow does not point to Regen a regeneration will not occur on Saturday.

Press SET HOUR to exit Installer Displays & Settings.

NOTE: If all arrows are turned off in d1-d7, Days to Regen in the User Displays will always read 7 and a regeneration will never occur.

User Displays & Settings

General Operation

When the system is operating one of two displays will be shown. Pressing UP or DOWN button will alternate between the displays. One of the displays is always the current time of day (to the nearest hour). The second display is the days remaining until the next regeneration. If the days remaining is equal to one, a regeneration will occur at the next preset regeneration time. The user can scroll between displays as desired.

If the system has called for a regeneration that will occur at the preset time of regeneration, the arrow will point to Regen.

Regeneration Mode

Typically a system is set to regenerate at a time of low water usage. An example of a time with low water usage is when a household is asleep. If there is a demand for water when the system is regenerating, untreated water will be used.

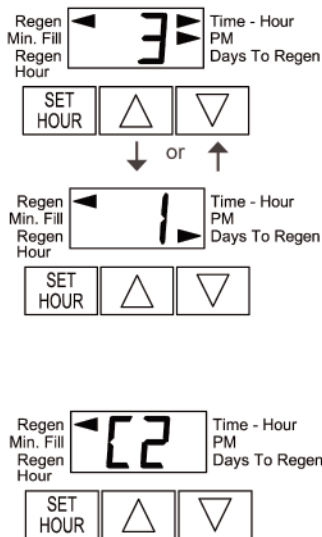

When the system begins to regenerate, the display will change to indicate the cycle of the regeneration process (see Table 1, page 4) that is occurring and an arrow will also point to Regen. The system will run through the steps automatically and will reset itself to provide treated water when the regeneration is completed.

Manual Regeneration

Sometimes there is a need to regenerate the system sooner than when the system calls for it, usually referred to as a manual regeneration. There may be a period of heavy water usage because of guests or a heavy laundry day.

To initiate a manual regeneration at the preset delayed regeneration time, simultaneously press UP + DOWN buttons together and release. The arrow will point to the word Regen if a regeneration is expected "tonight." To cancel the regeneration, simultaneously press UP + DOWN buttons and release.

To initiate a manual regeneration immediately, simultaneously press UP + DOWN buttons together for three seconds. The system will begin to regenerate immediately. The request cannot be cancelled.

Note: For softeners, if brine tank does not contain salt, fill with salt and wait at least two hours before regenerating.

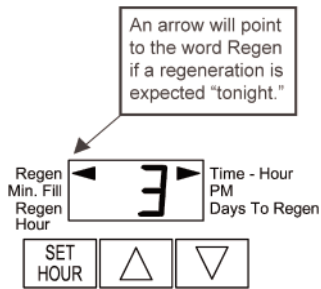

Set Time of Day

STEP 1-TD – Press SET HOUR

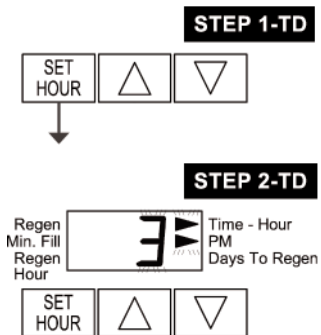

STEP 2-TD – *Current time:* Set the clock to the closest hour by using the UP and DOWN button. An arrow points to PM after 12. After a power outage, the time of day will need to be reset.

Press SET HOUR to exit.

Power Loss

If the power goes out, the current time of day will need to be reset. If the power goes out while the system is regenerating, the cycle picks up where it was interrupted when the power returns.

Error Message

If "E1," "E2," or "E3" appears on the display, contact the OEM for help. This indicates that the valve did not function properly.

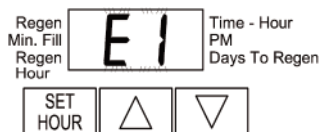

Drawings and Part Numbers

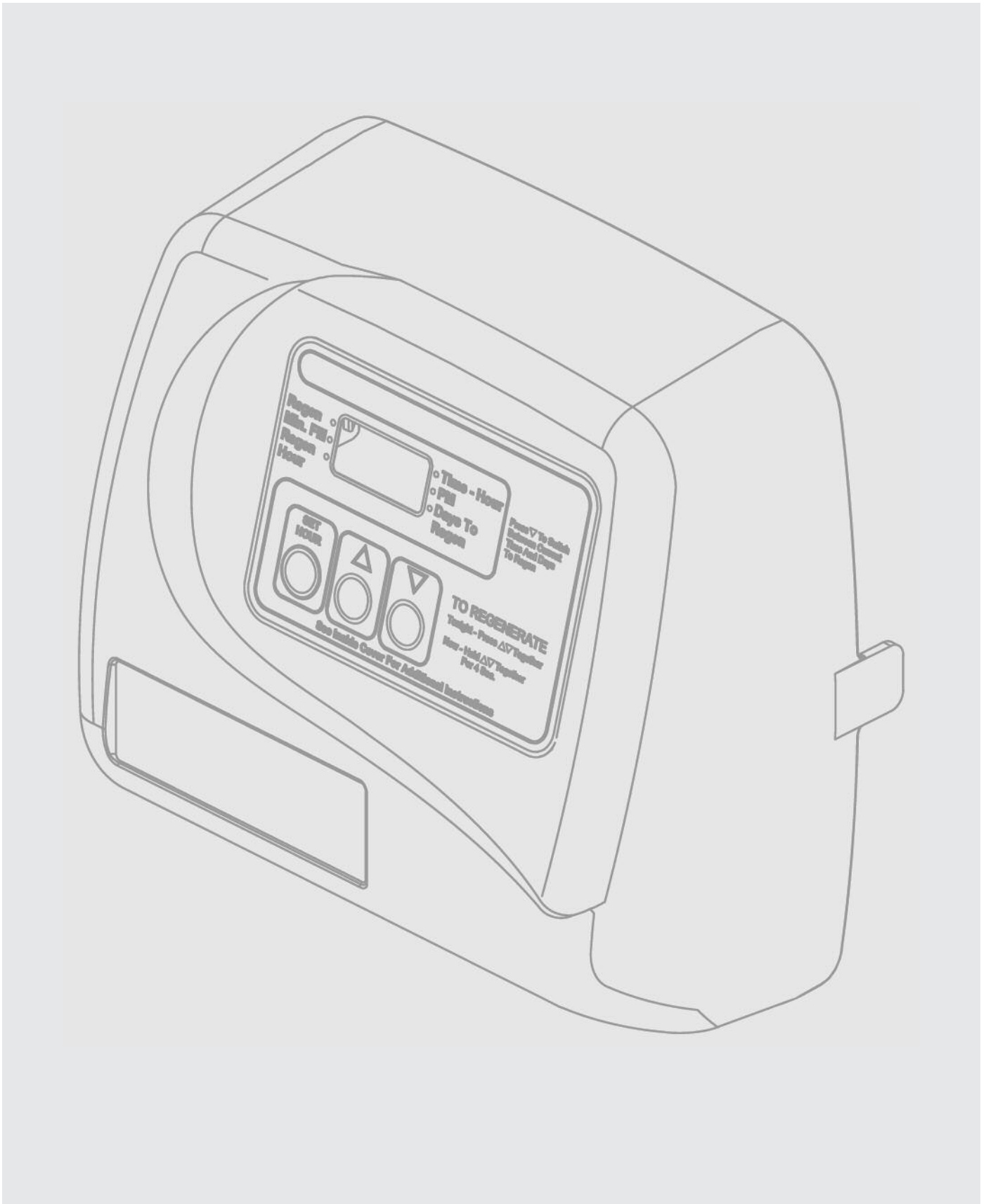

Front Cover and Drive Assembly

Drawing No.	Part No.	Description	Quantity
1	LC-V3175TC-01	WS1TC Front Cover Assembly	1
*	LC-V3002TC *	WS1TC Drive Assembly	1
2	LC-V3107-01	WS1 Motor	1
3	LC-V3106-01	WS1 Drive Bracket and Spring Clip	1
4	LC-V3108TC	WS1TC PC Board	1
5	LC-V3110	WS1 Drive Reducing Gear 12 x 36	3
6	LC-V3109	WS1 Drive Gear Cover	1
Not Shown	LC-V3186	WS1 AC Adapter 110V-12V	1
	LC-V3186EU	WS1 AC Adapter 220-240V-12V EU	1
	LC-V3186UK	WS1 AC Adapter 220-240V-12V UK	1
	LC-V3186-01	WS1 AC Adapter Cord Only	1

* Drawing Number Parts 2 through 6 may be purchased as a complete assembly: Part No. LC-V3002TC, WS1TC Drive Assembly.

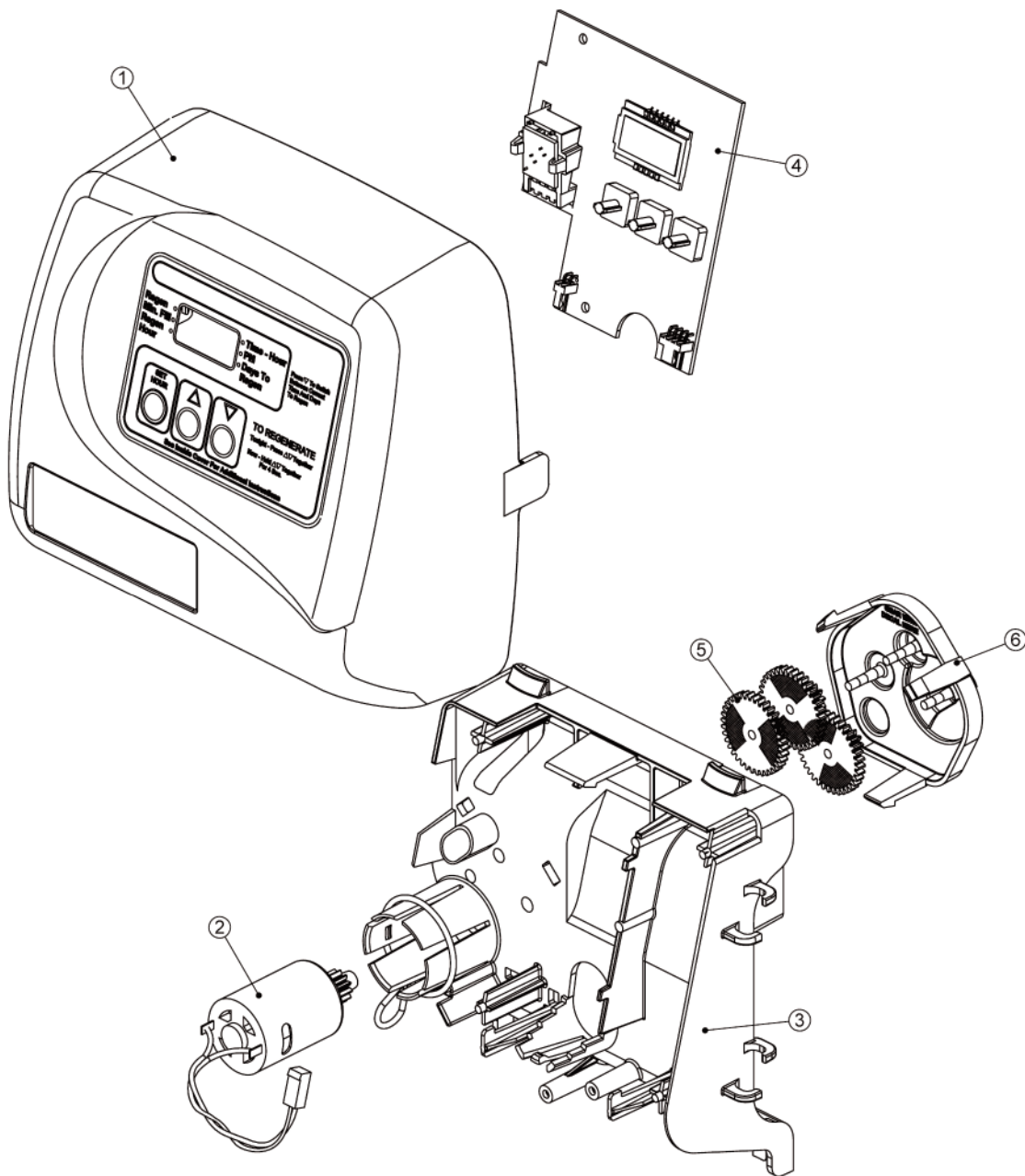

WS1TC Drive Cap Assembly, Downflow Piston, Regenerant Piston, and Spacer Stack Assembly

Drawing No.	Part No.	Description	Quantity
1	LC-V3005	WS1 Spacer Stack Assembly	1
2	LC-V3004	Drive Cap Assembly	1
3	LC-V3178	WS1 Drive Backplate	1
4	LC-V3011	WS1 Piston Downflow Assembly	1
5	LC-V3174	WS1 Regenerant Piston	1
6	LC-V3135	O-ring 228	1
7	LC-V3180	O-ring 337	1
8	LC-V3105	O-ring 215 (Distributor Tube)	1
Not Shown	LC-V3001	WS1 Body Downflow Assembly	1
	LC-V3001-02	WS1 Mixing Valve Body Assembly	1

NOTE: The regenerant piston is not used in backwash only applications.

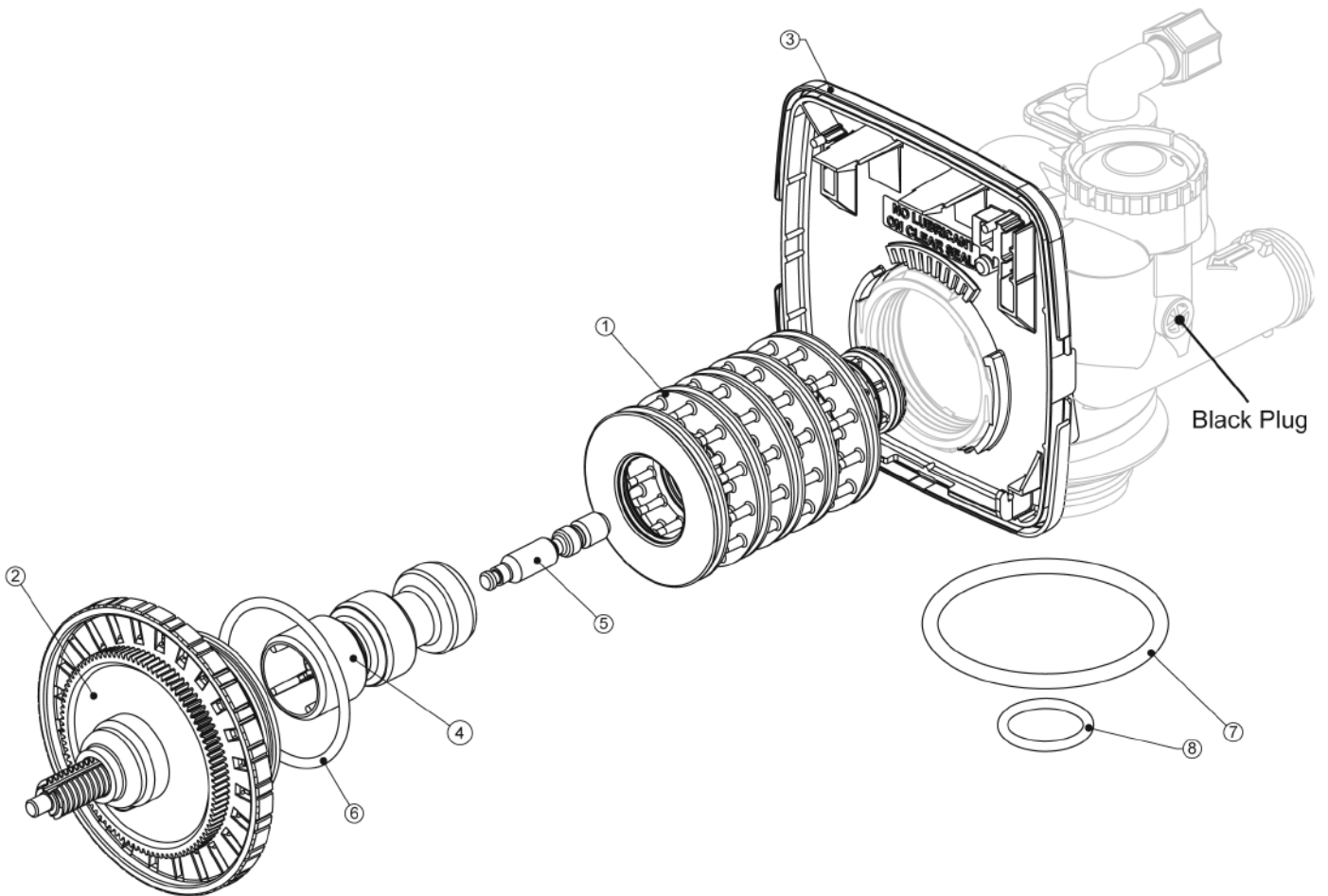

WS1.25TC Drive Cap Assembly, Downflow Piston, Regenerant Piston, and Spacer Stack Assembly

Drawing No.	Part No.	Description	Quantity
1	LC-V3430	WS1.5 Spacer Stack Assembly	1
2	LC-V3004	Drive Cap Assembly	1
3	LC-V3178	WS1 Drive Backplate	1
4	LC-V3407	WS1.5 Piston Downflow Assembly	1
5	LC-V3174	WS1 Regenerant Piston	1
6	LC-V3135	O-ring 228	1
7	LC-V3180	O-ring 337	1
8	LC-V3358	O-ring 219 (Distributor Tube Opening 1.32 inch)	1
	LC-V3357	O-ring 218 (Distributor Tube Opening 32mm)	1
Not Shown	LC-V3020	WS1.25 Body Downflow Assembly (Distributor Tube Opening 1.32 inch)	1
	LC-V3020-01	WS1.25 Mixing Valve Body Downflow Assembly (Distributor Tube Opening 1.32 inch)	1
	LC-V3020-02	WS1.25 Body Downflow Assembly (Distributor Tube Opening 32mm)	1
	LC-V3020-03	WS1.25 Mixing Valve Body Downflow Assembly (Distributor Tube Opening 32mm)	1

NOTE: The regenerant piston is not used in backwash only applications.

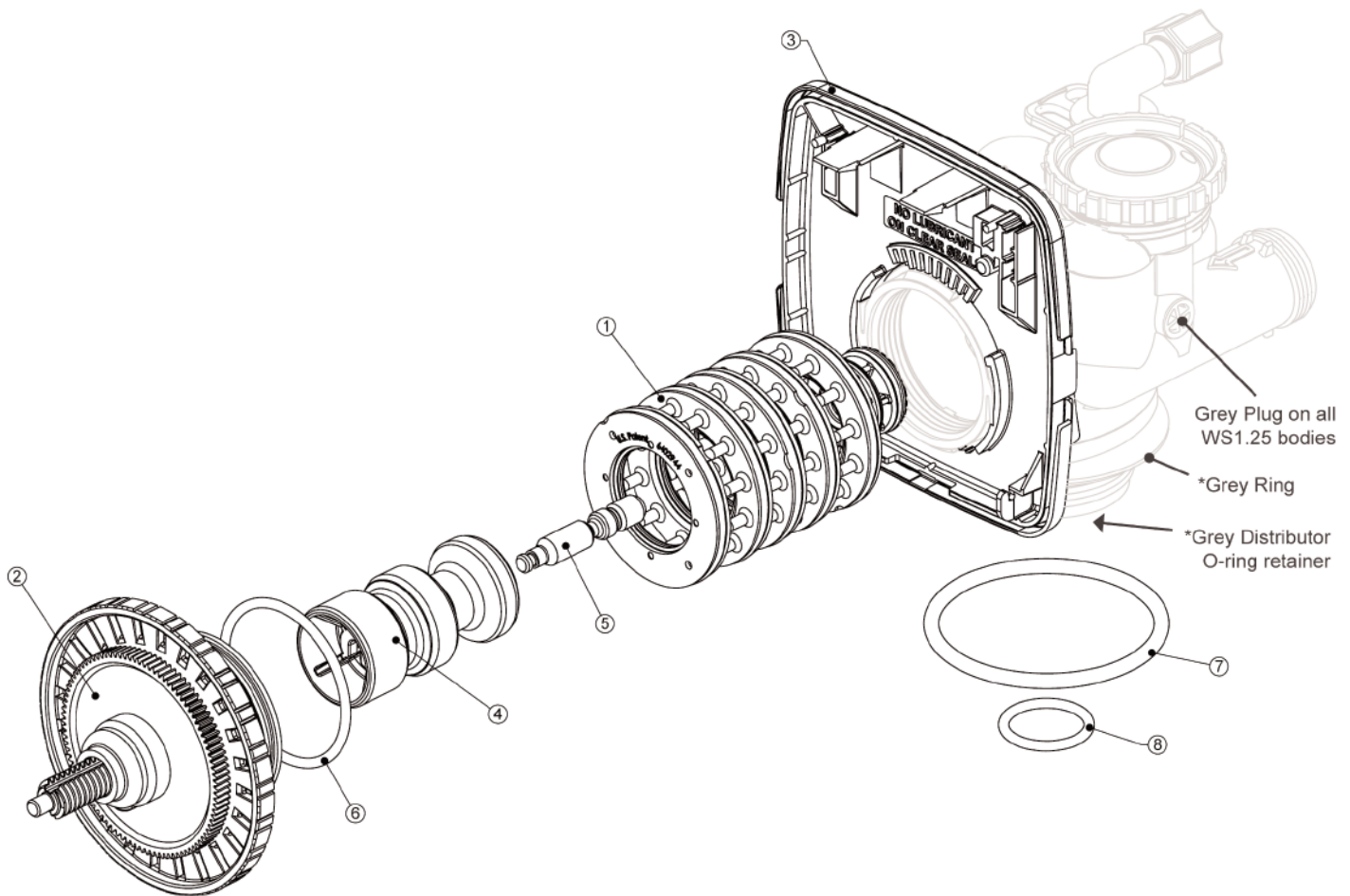

*Only for valves that have a 32mm Distributor Tube Opening

Figure 6: WS1 & WS1.25 Identification

WS1 with 1.050 inch Distributer Tube Opening Identification

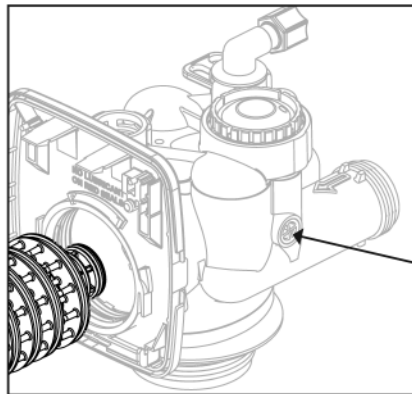

Black Plug

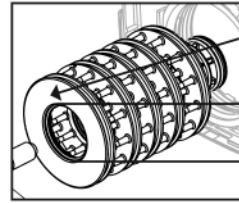

Spacer Color: Black

1.25 inch

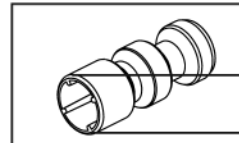

1.25 inch

NOTE: The WS1 downflow piston is a solid amber color.
The WS1 upflow piston is black and amber.

WS1.25 with 1.32 inch Distributer Tube Opening Identification

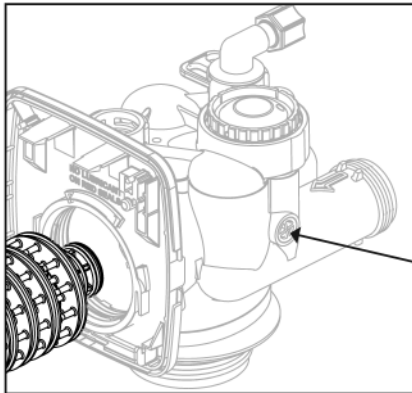

Grey Plug

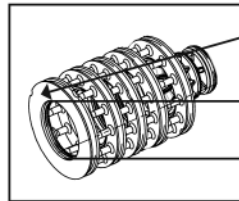

Spacer Color: Black

1.5 inch

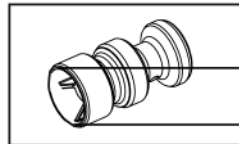

1.5 inch

WS1.25 with 32mm Distributer Tube Opening Identification

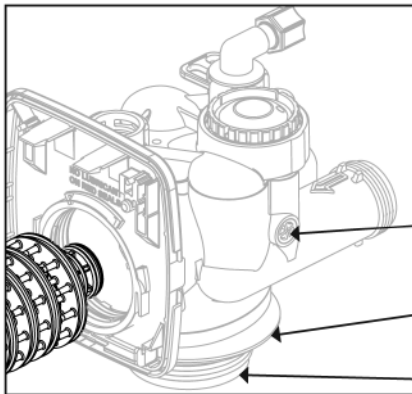

Grey Plug

Grey Ring

Grey
Distributor
O-ring
Retainer

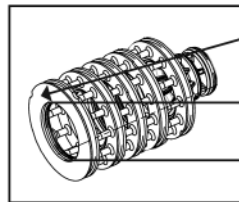

Spacer Color: Black

1.5 inch

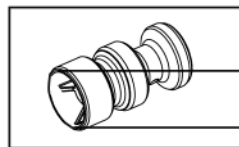

1.5 inch

