

# Series 150

Commercial/Industrial Control System  
Installation, Operation and Maintenance Manual



---

This page intentionally blank.

---

---

1.0 Installation Profile Summary	3
2.0 Logix 150 Valve Series	4
2.1 Master Chart	3
2.2 150 General Specifications	4
2.3 Dimensional Specifications	5
3.0 Introduction	7
3.1 Regenerant Line Piping	6
3.2 Installing the Tank Adapter and Valve-Top Mount	8
3.3 Installing Side Mount Adapter and Valve	9
3.4 Twin Alternating System Setup	10
3.5 Sequential Regeneration System Setup	11
4.0 General Logix Series Instructions	13
4.1 Display Icons Logix Controller	12
4.2 Keypad — Buttons	13
5.0 Programming Your Control	15
6.0 Logix Controller	20
6.1 700 Series Initial Power-Up	20
6.2 Level I Parameters	20
6.3 Specific Day of Week Regeneration (7-Day Timer)	22
7.0 Things You Might Need to Know	23
8.0 Placing Conditioner Into Operation	24
9.0 Regeneration Modes	26
9.1 Remote Regeneration — Dry Contact Input	27
10.0 Programming the Logix for Manganese Greensand Systems	28
11.0 742/762 Level II Programming	29
11.1 Locking/Unlocking Parameters	29
11.2 Explanation of Level II Parameters	30
12.0 Cycle Time Programming	31
12.1 Auxiliary Relay Programming	32
13.0 Accessing History Values	33
13.1 Maintenance Interval	34
14.0 Control Reset	35
15.0 Electrical Drawings	36

---

16.0 Troubleshooting	40
16.1 Troubleshooting: Logix Controller	40
16.2 Troubleshooting: 150 Valve	41
16.3 Flow Diagrams	43
17.0 Performance	44
17.1 Pressure Drop vs. Flow	44
17.2 Injector Charts	44
17.3 Backwash Control Sizing	47
18.0 Replacement Parts - Valve	48

# DECLARATION OF CONFORMITY



## Rockford Operations

This Declaration of Conformity applies to the Series 150 Valve with a Logix Controller as used for a Twin Alternating Water Conditioning System.

**Manufacturer:** General Electric Rockford Operations  
2412 Grant Ave.  
Rockford, IL 61103-3991  
USA

This equipment has passed testing for conformity to the following standards:

### Emissions:

Standard EN 55011 Class B - Conducted Emissions, AC Mains; 0.15 - 30 MHz  
RF Radiated Emissions; 30 - 1000 MHz

### Immunity:

Standard EN 61326:2003: Table A.1

Enclosure	ESD	8 kV Air 4 kV Contact
Enclosure	RF EM Field	10 V/m; 80 - 1000 MHz
AC Power	Fast Transients	1.0 kV 5/50 nSec
Signal Lines	Fast Transients	0.5 kV 5/50 nSec
AC Power	Surges	1 kV Diff.; 2kV Comm.
Signal Leads	RF Conducted	3 V; 0.15 - 80 MHz
AC Power	RF Conducted	3 V; 0.15 - 80 MHz
Enclosure	Magnetic Fields	3 A/m; 50 Hz
AC Power	Voltage dips	0% 0.5 and 1 Cycle

GE Product Family Testing

Document, CENELEC EN 61326 (2003) Electrical Equipment for Measurement, Control, and Laboratory Use - EMC Requirements. This equipment complied with all applicable tests as required for industrial devices.

---

---

## CAUTION AND WARNING SYMBOLS

The following international symbols appear in this manual to highlight caution and warning messages.



**Caution:** Failure to follow this instruction can result in personal injury or damage to the equipment.

---



**Warning:** Not heeding these messages could result in serious personal injury. This symbol is intended to alert the user to the presence of "dangerous voltage" within the product's enclosure that may be of sufficient magnitude to constitute a risk of electric shock to persons.

---



**Warning: Class I equipment -** To avoid electric shock proper electrical grounding of the system is required. Electrical installation should be completed by qualified electricians and in accordance with the requirements of all state and local electrical codes as well as the National Electrical Code (NEC). A separate ground terminal has been provided inside this equipment and is indicated by the NEC ground symbol as shown below.



NEC Ground Symbol  
(Green w/White Background)

---



**Warning: Overcurrent Protection -** This equipment is supplied with built-in overcurrent protection (5 amp fuse, slow-blow). The system relies on the protective devices in the installation location for protection against short-circuit, overcurrent, and earth (grounding) fault. Ensure that the protective devices in the building installation are properly rated to protect the system, and that they comply with national and local codes. The external switch and/or circuit breaker must be in close proximity to this equipment and in easy reach of the operator. It must be clearly marked to indicate that it is the disconnecting device for this equipment. Recommended breaker size is 15 amp. A qualified electrician should perform all electrical installation and verify safe operation of all electrical systems associated with this equipment.

---

# 1.0 Installation Profile Summary

Installation Date: \_\_\_\_\_

Installation Company: \_\_\_\_\_

Installer(s): \_\_\_\_\_

Installer(s) Phone Number: \_\_\_\_\_

Application Type: (Softener) (Filter) (Dealkalizer)

### Water Source:

(Public Well) (Private Well) (City)

(Surface Supply)

(Other)

### Water Test Results:

Hardness: \_\_\_\_\_ Iron: \_\_\_\_\_

Total Alkalinity: \_\_\_\_\_

pH: \_\_\_\_\_

H<sub>2</sub>S: \_\_\_\_\_

Manganese: \_\_\_\_\_

TDS: \_\_\_\_\_

Other: \_\_\_\_\_

### Misc:

Flow Rates: \_\_\_\_\_ min. \_\_\_\_\_ max.

Tank Size: Diameter \_\_\_\_\_ Height: \_\_\_\_\_

Resin or Media Volume: \_\_\_\_\_

Resin or Media Type: \_\_\_\_\_

Brine Tank Size: \_\_\_\_\_

### Control Valve Configuration:

Valve Model:

\_\_\_\_\_ 150 Single Conditioner

\_\_\_\_\_ 2150 Twin Alternating Conditioner

\_\_\_\_\_ 153 Single Filter

\_\_\_\_\_ 2153 Twin Alternating Filter

\_\_\_\_\_ Sequential Regeneration

(Hard Water Bypass) (No Hard Water Bypass)

Injector: (150-R) (150-A) (150-B) (150-C) (150-D) (Plugged)

Backwash Control: \_\_\_\_\_ gpm

External Refill Control \_\_\_\_\_ gpm

### Electronic Demand Settings

P1 Time of day \_\_\_\_\_

P2 Day of week \_\_\_\_\_

P3 Time of regeneration \_\_\_\_\_

P4 Number of days between regeneration (99 day calendar override) \_\_\_\_\_

P5 Day of week regeneration \_\_\_\_\_

### Regeneration Frequency:

S M T W T F S

P6 Amount of regenerant used for filter backwash time (salt setting) \_\_\_\_\_

P7 System capacity \_\_\_\_\_

P8 Hardness \_\_\_\_\_

P9 Units of measure \_\_\_\_\_

P10 Clock mode \_\_\_\_\_

P11 Service interval \_\_\_\_\_

P12 Remote regeneration switch delay \_\_\_\_\_

P14 Refill rate (conditioner only) \_\_\_\_\_

P15 Draw rate (conditioner only) \_\_\_\_\_

P16 Reserve type \_\_\_\_\_

P17 Initial average or fixed reserve \_\_\_\_\_

P18 Flow sensor select \_\_\_\_\_

P19 K-factor or pulse equivalent \_\_\_\_\_

# 2.0 Logix 150 Valve Series

## 2.1 Master Chart

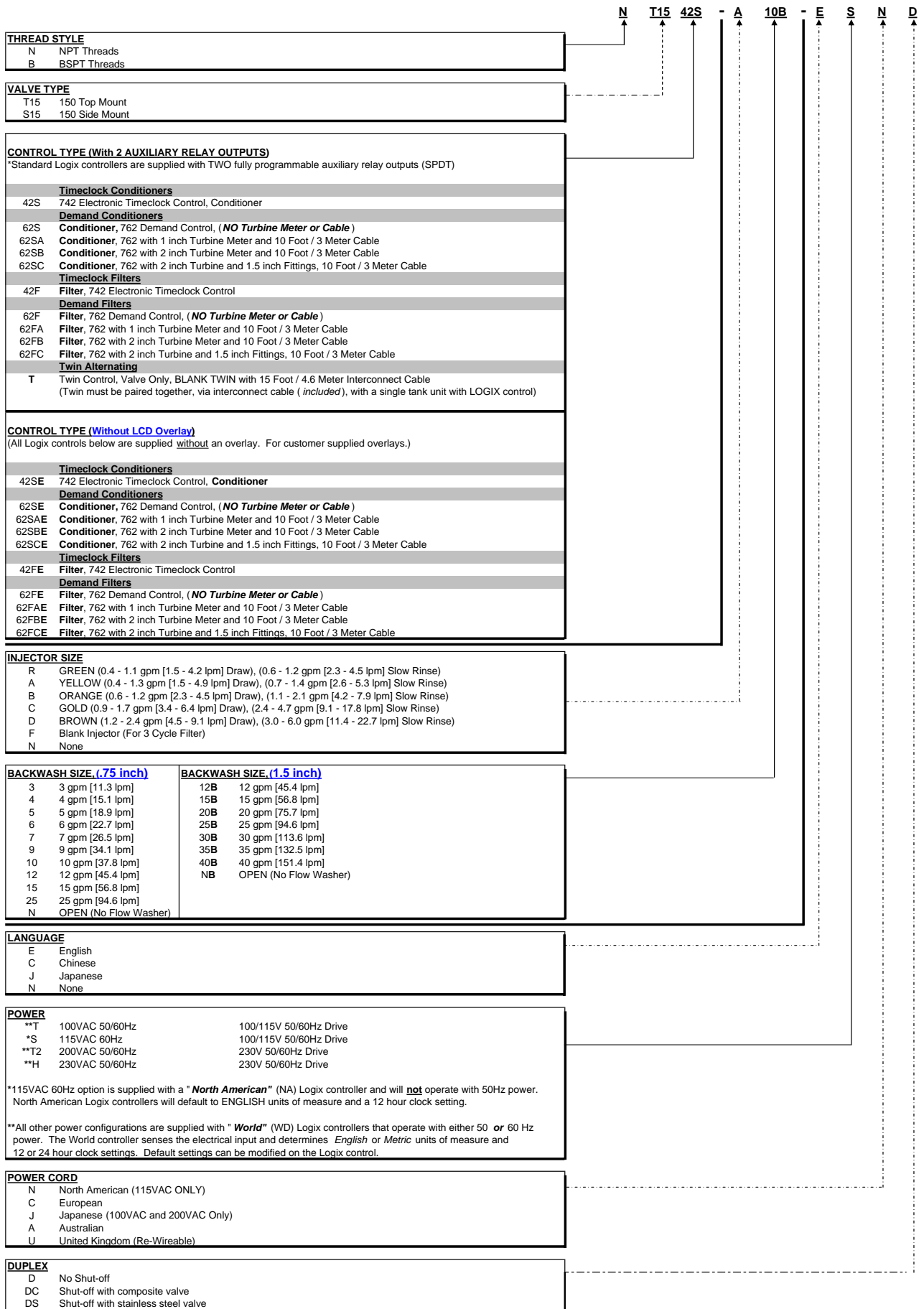

## 2.2 150 General Specifications

### NEMA 4/IP65 Style Enclosure

Intended for indoor or outdoor use primarily to provide a degree of protection against corrosion, windblown dust and rain, splashing water, and hose-directed water; undamaged by the formation of ice on the enclosure. The enclosure door must be kept tightly closed. Any modifications to this product (i.e. added holes for cable entry/mounting, conduit connections... etc.) may void the intended NEMA4/IP65 rating. NEMA 4/IP65 and UL rated fittings should be used when modifying the enclosure.

### Inputs

**Terminal Strip 1 (TB1) High Voltage** (Connection provided via power cord, supplied by manufacturer)

TB1, Terminal "L": Line Voltage Input

TB2, Terminal "N": Neutral Input

Earth Ground, Terminal Post and Nuts located on motor plate. Identified by 

### Outputs

**Terminal Strip 2 (TB2) and 3 (TB3) High Voltage**

Terminal "NC": Normally Closed Auxiliary Relay Contact Output

Terminal "NO": Normally Open Auxiliary Relay Contact Output

Terminal "L": Line Voltage Output (can be used to provide power to input "C").

### Relative Humidity Operating Range

1 to 65°C (34 to 150°F)	10% to 100% Condensing
38 to 55°C (100 to 131°F)	10% to 75% Non-Condensing
Pollution Degree	2
Overvoltage Category	11
Max. Rated Power	125 Watts
Altitude	6500 feet (2000 m)
Working Pressure	20 to 125 psi (1.4 to 8.6 bar)
Voltage Range	100 to 230 VAC (±10%)
Standard Electrical Rating	115 VAC, 230 VAC, 100 VAC, 200 VAC, 50/60 Hz
Electrical Cord Length	6 feet (1.8 m)
Electrical Connection	Terminal strip
Standard Plumbing Connections	1-1/2 in NPT/BSPT inlet and 1/2 inch NPT regenerant / 3/4 inch NPT/BSPT drain
Optional Plumbing Connections	1-1/2 inch NPT/BSPT drain
Rubber Parts	EPDM (NSF61 and WRAS Approved)
Valve Body	CF8M (316) Stainless Steel (Passivated)
Injector	5 sizes available, (refer to Injector Flow Rate Chart)
Logix Control	742 Electronic Time Clock, 762 Demand Systems Conditioner and Filter Versions Available
Backwash Cycle	0-250 minutes
Regenerant Draw Cycle	0-250 minutes
Slow Rinse Cycle	0-250 minutes
Fast Rinse Cycle	0-250 minutes
External Backwash Controller Required (over 40 gpm)	
External Regenerant Valve Required	Must have positive shut-off on refill and draw down
Ambient Temperature	34°F (1°C) to 150°F (65°C)
Fluid Temperature Range	34°F (1°C) to 180°F (82°C)
Riser Pipe Diameter Required	1-1/2 in schedule 40 PVC (42 mm O.D. x 3.8 mm wall)
Tank Adapters (Top Mount)	4 inch - 8 UN Thread with 1-1/2 inch Riser (42mm)
Tank Adapters (Side Mount)	1-1/2 inch NPT/BSPT

## 2.3 Dimensional Specifications

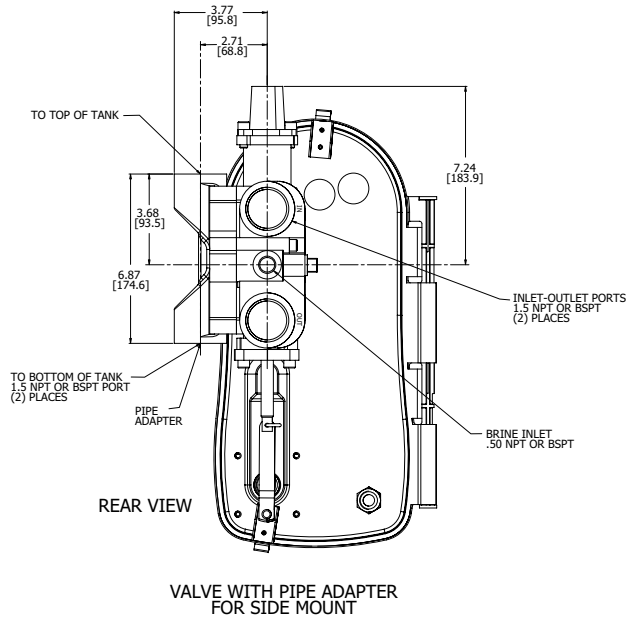
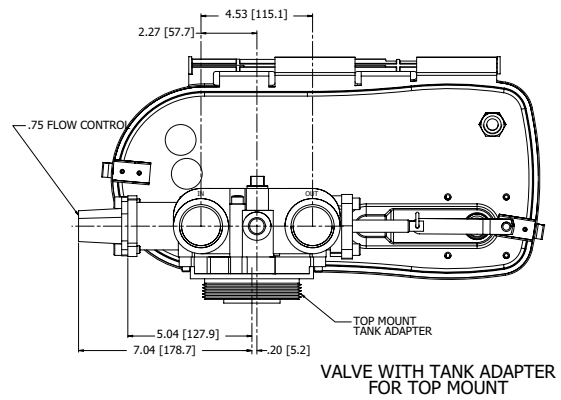
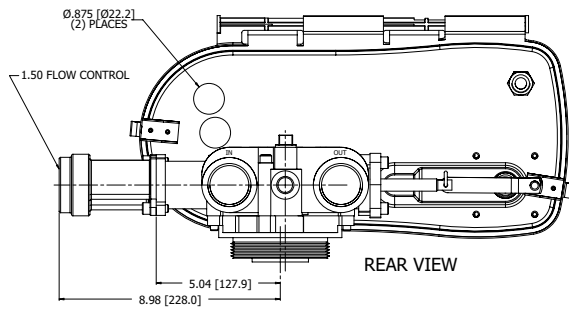
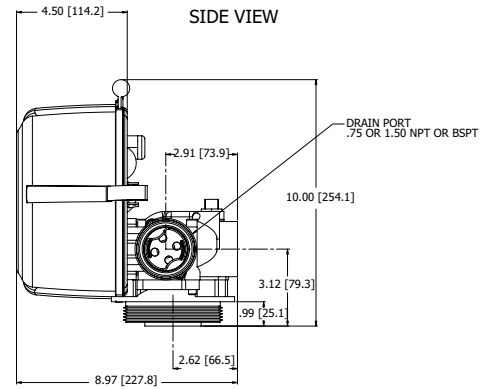
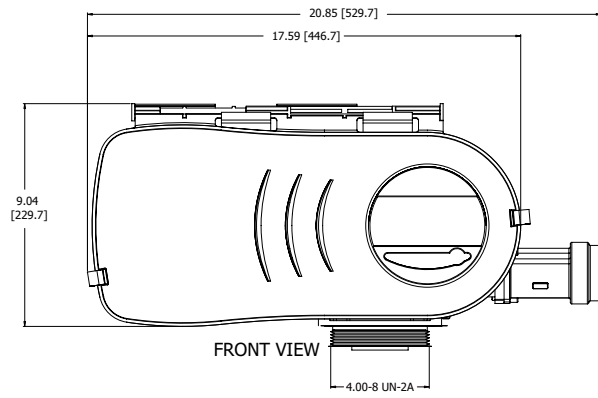

INCHES [MILLIMETERS]  
NOTE: DIMENSIONS ARE SHOWN FOR REFERENCE ONLY

## 3.0 Introduction

### General Installation Information

The water conditioner should be assembled, piped and wired according to the water treatment equipment manufacturer's recommendations and local requirements. The following instructions are provided as a general guide. Figure 1 through Figure 6 illustrate typical installations.

### Inlet and Outlet Piping

All inlet and outlet piping should be anchored or supported adequately to avoid stress on the control system. Follow good plumbing practices and conform to local codes. Provide shut-offs and emergency bypass of unconditioned water in the event the unit requires servicing.

### 3.1 Regenerant Line Piping

The 1/2-inch NPT regenerant connection is located between the inlet and outlet pipe connections of the control valve.

Regenerant line diameter should be no smaller than 1/2 inch. The regenerant line should be self-supporting. Regenerant line length should be less than 20 feet (6 meters) with a maximum lift of 6 feet (1.8 meters) to assure unrestricted regenerant draw. Consult factory for installations outside of these recommendations.

A float type regenerant valve must be used in the regenerant tank to control salt dosage as well as for safety purposes. Since the regenerant line is normally pressurized, a manual shut-off valve should be installed to facilitate regenerant system servicing.

### Drain Line Piping

The drain line housing is available in either 3/4 or 1-1/2 inch, NPT or BSPT.

To avoid improper operation of the equipment the following drain line precautions should be observed.

- Drain line piping should be same size as flow control, do not reduce pipe size.
- Overall drain line length less than 20 feet (6.1 m).
- Do not install manual valves in the drain line.
- Minimize number of elbows and fittings.
- Piping must be self supporting.
- Install vacuum break if drain line siphon is likely.
- Provide air gap to comply with plumbing code.

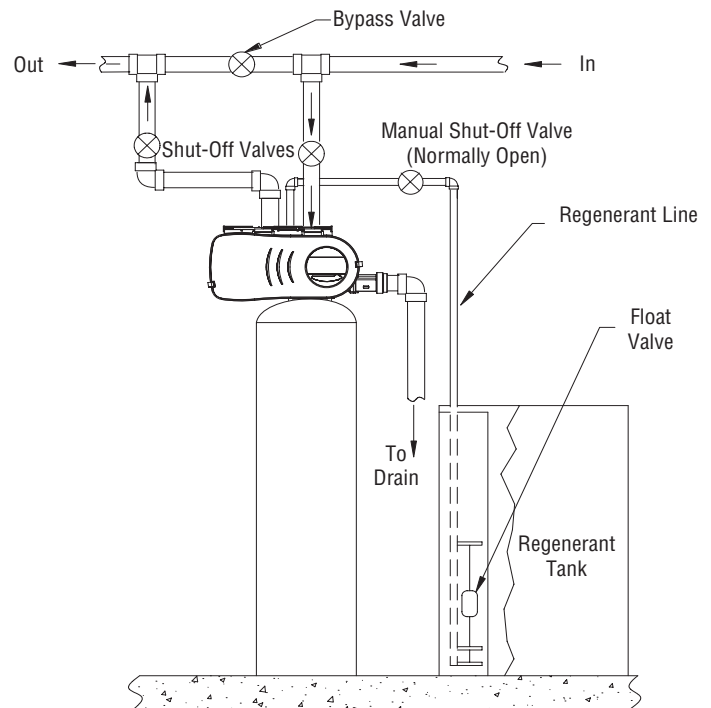

Figure 1 Typical Top Mount Installation

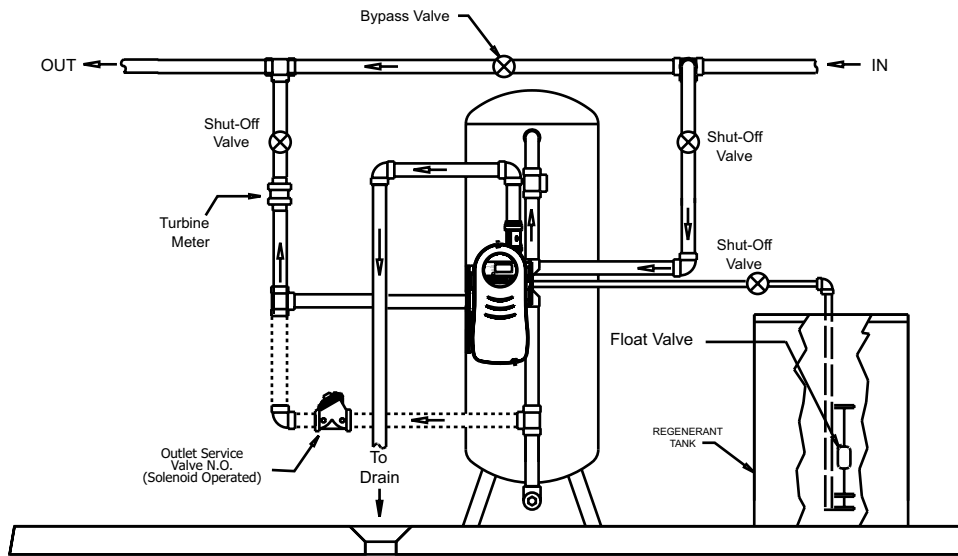

Figure 2 Typical Side Mount Installation

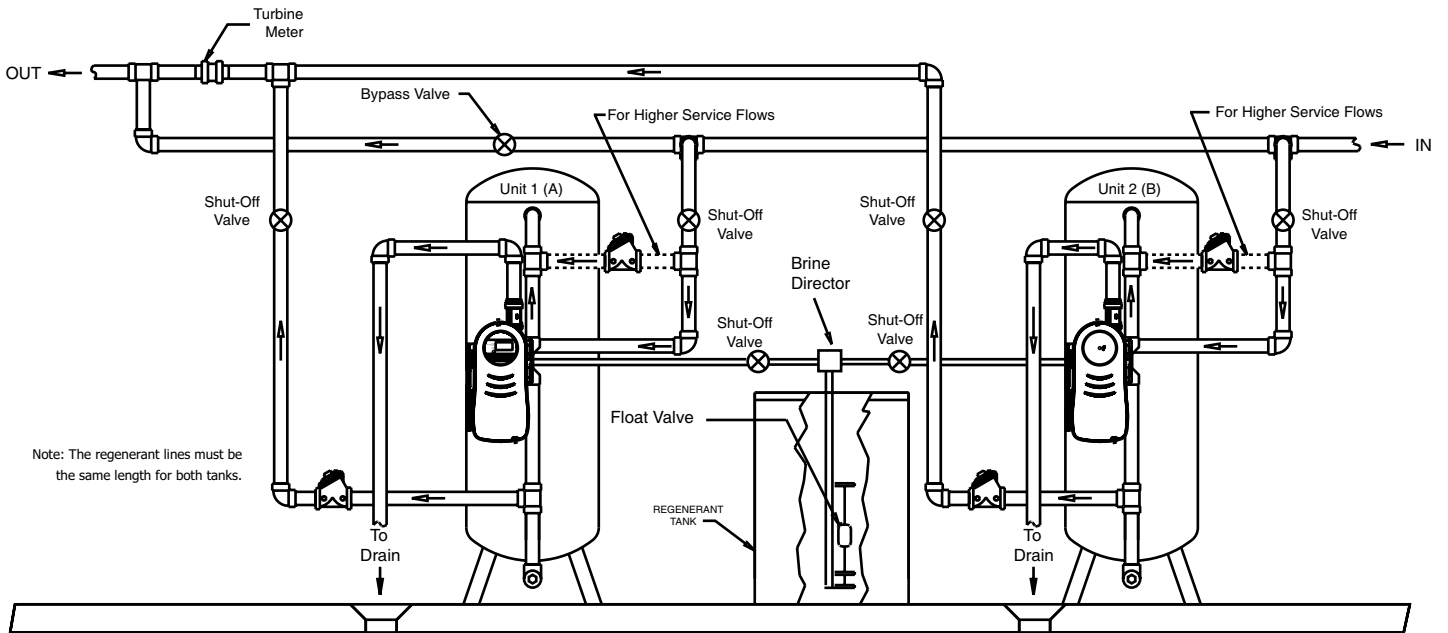

Figure 3 Typical Twin Alternating Side Mount Installation

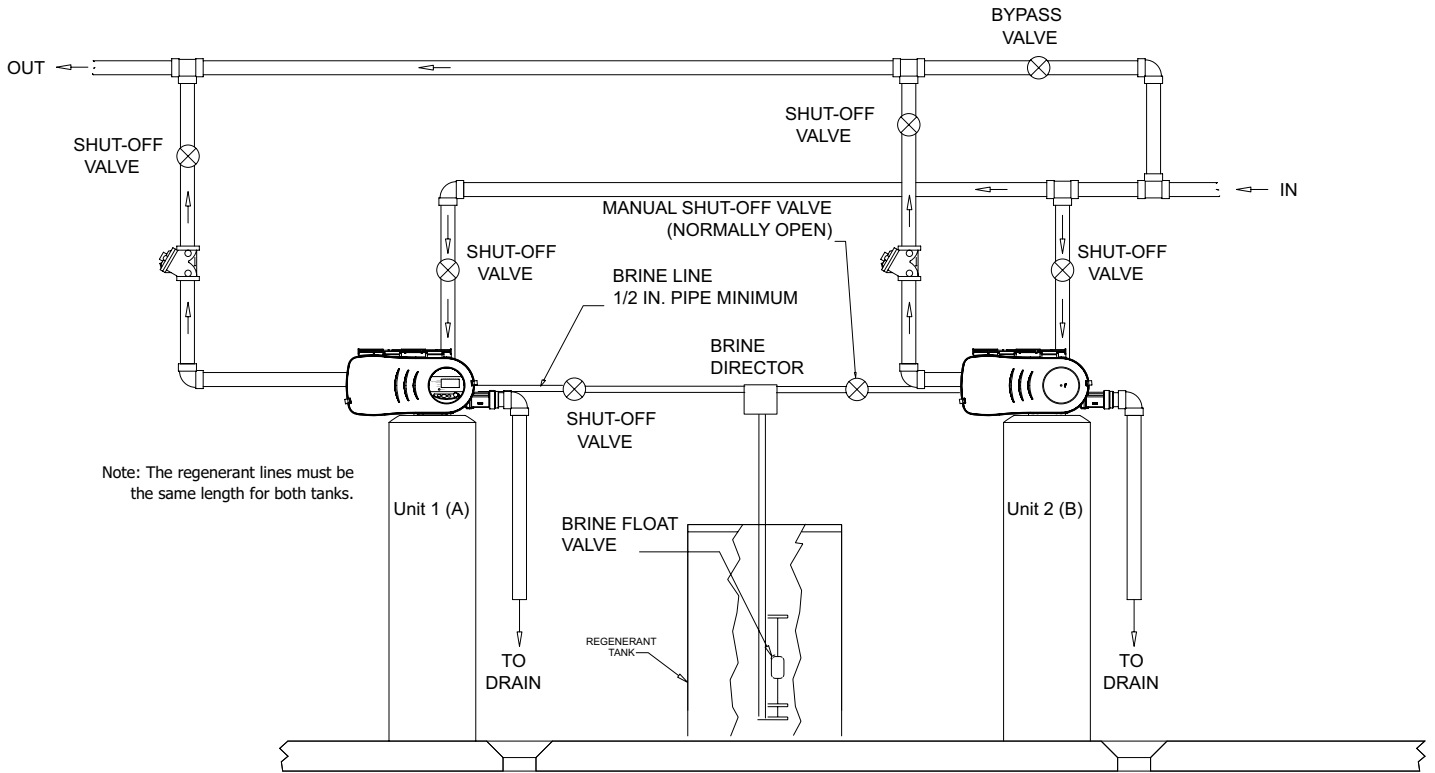

Figure 4 Typical Twin Alternating Top Mount Installation

### 3.2 Installing the Tank Adapter and Valve-Top Mount

1. Make sure the riser pipe is 1/4-inch ± 1/8-inch ( 6 mm ± 3 mm) below the top of the tank, Figure 6.
2. Apply silicone grease to all O-rings (Figure 5), the bevel on top of the tank and to the top 1 inch of the riser pipe.
3. Place the gasket on the tank adapter and position the valve.
4. Mount the valve using the five allen screws and tighten evenly with wrench provided.
5. With the tank empty, thread the tank adapter into the tank and tighten until the tank adapter bottoms out on the tank. Align valve with plumbing.
6. Remove valve from tank.
7. Fill tank with media.
8. Clean residual mineral from top of the tank and threads.
9. Remount the valve (see step 4).

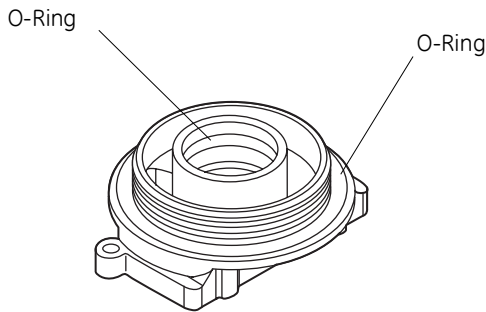

Figure 5

3. Place the gasket on the tank adapter and position the valve.
4. Mount the valve using the five allen screws and tighten evenly with wrench provided.
5. With the tank empty, thread the tank adapter into the tank and tighten until the tank adapter bottoms out on the tank. Align valve with plumbing.

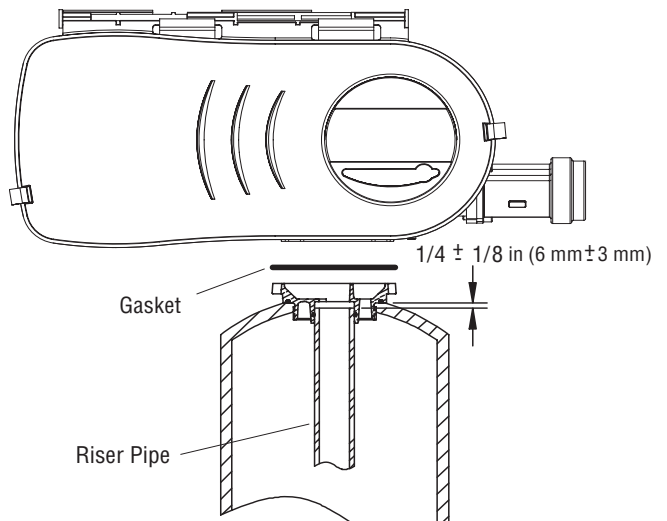

Figure 6 Layout for Top Mount

### 3.3 Installing Side Mount Adapter and Valve

1. Position the valve body on the side mount adapter with the gasket in place, Figure 7.
2. Mount the valve using the five Allen screws provided and tighten evenly with wrench provided.

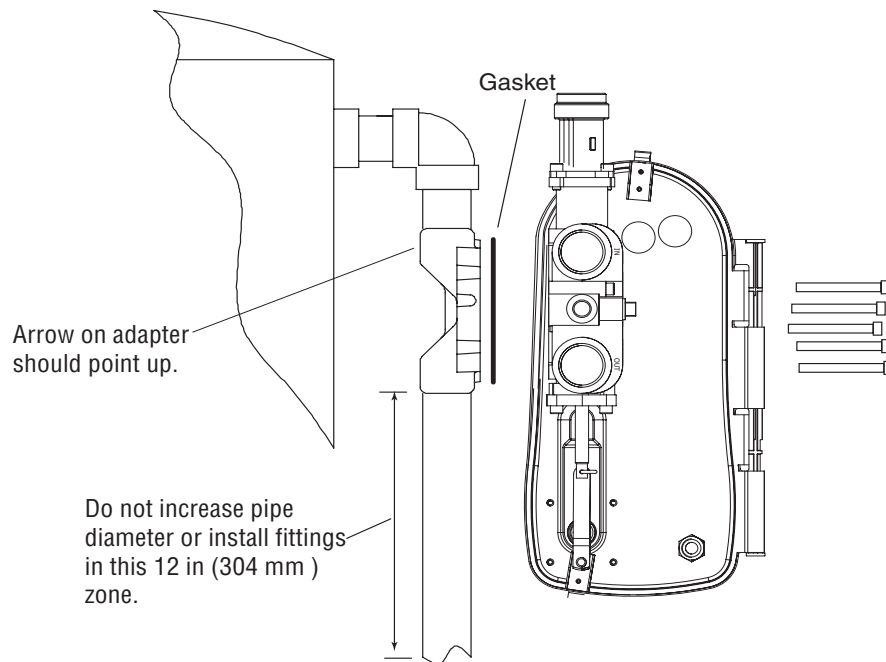

Figure 7 Layout for Side Mount

### 3.4 Twin Alternating System Setup

The 762 and 742 controls can be used for twin alternating systems. These systems operate with one unit online and with the other in standby. Typical twin alternating connections are shown in Figure 8.

**NOTE:** Auxiliary relay outputs "A" and "b" are not programmable in twin alternating mode.

**NOTE:** Select valve type 2150 (conditioner) or 2153 (Filter) when programming twin alternating units.

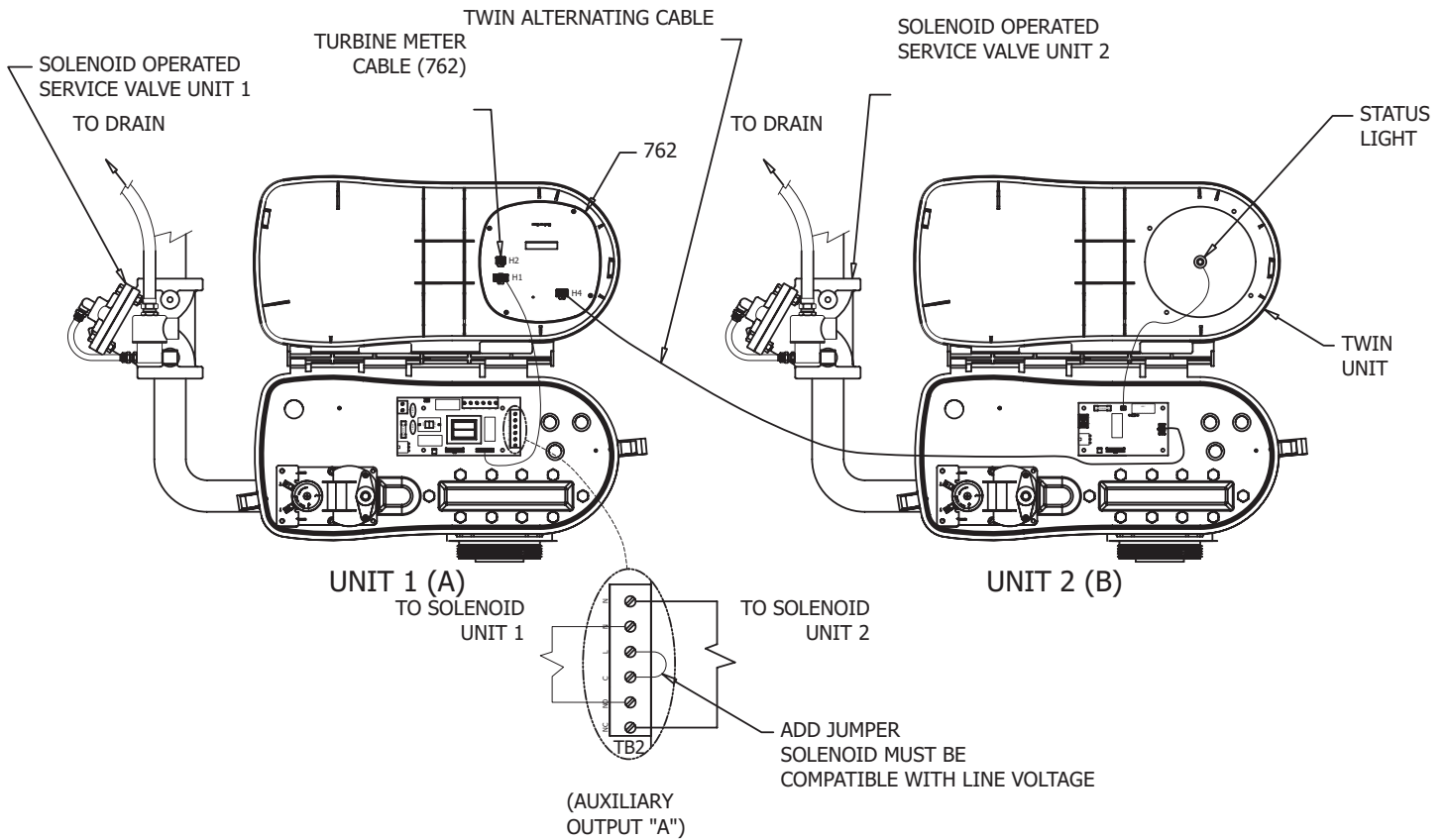

Figure 8 Typical Twin Alternating Control Layout.

### 3.5 Sequential Regeneration System Setup

The 762 and 742 controls can be used in sequential regenerating systems. These systems are connected in parallel with all units online except when in regeneration. Regeneration occurs one unit after another with the regeneration completion from one unit starting the regeneration of the next unit. Typical sequential regeneration connections are shown in Figure 9.

**NOTE:** Select valve type 150 (conditioner) or 153 (filter) when programming sequential regenerating units.

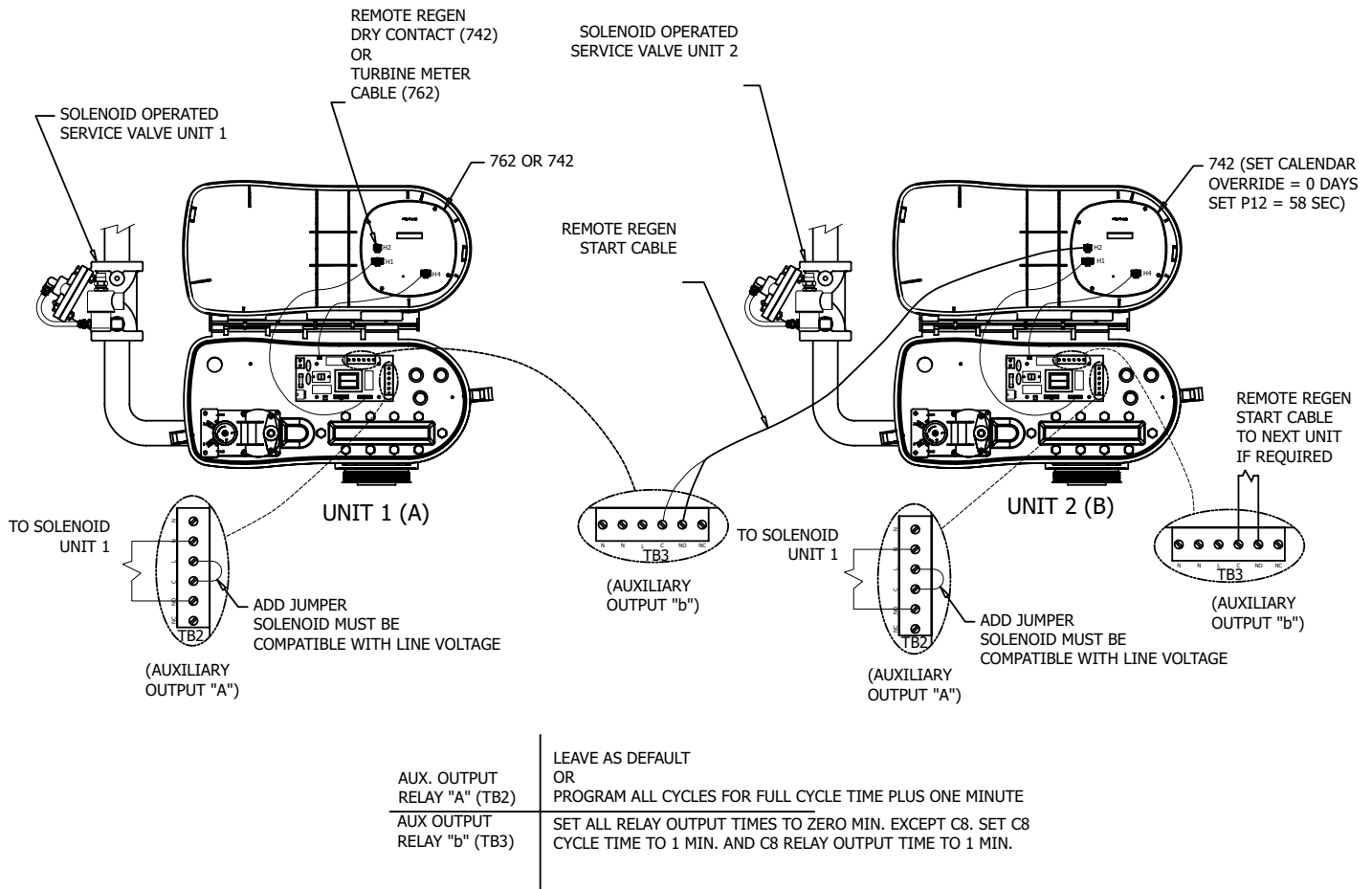

Figure 9 Typical Sequential Regenerating Layout.



21. Faucet is displayed when the current flow rate is displayed. Control may show the faucet and "0", indicating no flow.
22. Maintenance interval display turns on if the months in service exceed the value programmed in P17.
23. Used with #24, #25, and #26. Displays a sequence number or a value.
24. History Values (H). The number displayed by #23 identifies which history value is currently displayed.
25. Parameter (P). Displayed only in Level II Programming. The number displayed by #23 identifies which parameter is currently displayed.
26. Cycle (C). The number displayed by #23 is the current cycle in the regeneration sequence.
27. Hardness setting—only used with 762 controllers.
28. Capacity display—shows estimated system capacity.

## 4.2 Keypad — Buttons

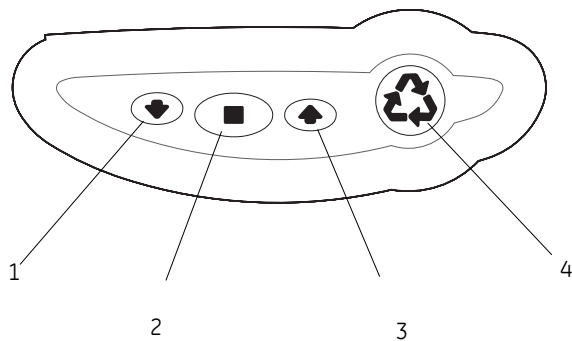



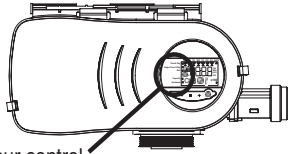

Figure 11

1. DOWN arrow  generally used to scroll down or increment through a group of choices.
2. SET  used to accept a setting that normally becomes stored in memory. Also used together with the arrow buttons.
3. UP arrow  generally used to scroll up or increment through a group of choices.
4. Regenerate  used to command the controller to regenerate. Also used to change the lock mode.

**NOTE:** If a button is not pushed for thirty seconds, the controller returns to normal operation mode.

## 5.0 Programming Your Control



Identify your control by matching the display text to the guide



■	SET
▲	UP
▼	DOWN
♻️	REGEN
🔒	LOCKED VALUE

	<b>762</b>	<b>742</b>	<b>762F</b>	<b>742F</b>
<b>Control:</b>	Time/Day Regeneration Time/Day Salt Amount  Capacity Hardness	Time/Day Regeneration Time/Day Salt Amount  Capacity	Time/Day Backwash Time/Day Backwash Length  Capacity	Time/Day Backwash Time/Day Backwash Length
<b>Regeneration Start</b>	Metered	Clock or Remote Signal	Metered	Clock or Remote Signal
<b>System Type:</b>	4-Cycle Conditioner	4-Cycle Conditioner	3-Cycle Filter	3-Cycle Filter
<b>Use Page:</b>	15	16	17	18

### General Program Reference Guide

#### To Change a Value:

- Use ▲ or ▼ to select value to change.
- Then press ■ until value blinks.
- Then use ▲ or ▼ to scroll through value options.
- Then press ■ to enter value.

**NOTE:** A locked value (🔒) cannot be changed until it is unlocked.

#### To Start Manual Regeneration:

- Press ♻️ for regeneration today.
- Hold ♻️ for 5 seconds for immediate regeneration.

#### During a Regeneration:

- Press ▲ or ▼ or ■ to view current cycle time remaining.
- Press ▲ AND ■ to advance cycles.
- Hold ▲ AND ■ for 5 seconds to cancel regeneration.

#### To Program Individual Cycle Times:

*Note: Only required to override current settings.*

- Hold ▲ AND ■ for 5 seconds.

- Then use ▲ or ▼ to scroll through cycles.  
C1 - Backwash  
C2 = Regenerant Draw  
C3 = Slow Rinse  
C5 = Fast Rinse  
C8 = Regenerant Refill
- Then press ■ until value blinks.
- Then use ▲ or ▼ to scroll.
- Then press ■ to enter value.

#### Setting the 7-Day Clock (742 and 742F only)

- Set the Days Override to "0".
- With arrow on "Regeneration Time/Day", press ■ until arrow flashes under desired day of week.
- Then use ▲ or ▼ until black bar is displayed indicating regeneration that day.
- Press ■ to advance to next day.

#### To Reset the Valve Type:

**NOTE:** All values are rest to factory defaults.

- Hold ▼ AND ■ for 5 seconds.
- When "HO" is displayed, hold ■ for 5 seconds.
- Then press ▲ or ▼ to change valve type.
- Then press ■ to enter displayed valve type.

# 150 Demand 762 4-Cycle Conditioner



Screen	Buttons to Press	Description	Range
	then ↓ or ↑ press ■	1. Valve Type — Select 150 for 4-Cycle Single tank conditioner or — Select 2150 for 4-Cycle Twin-Alternating conditioner	
	then ↓ or ↑ press ■	2. Resin Volume — Select correct resin volume	Cubic feet: 3.00 to 17.00 Liters: 75 to 500
	press ■ then ↓ or ↑ press ■	3. Time of Day (12 hr.) — Set to actual time of day Note: Setting includes PM indicator.	
	press ■ then ↓ or ↑ press ■	4. Day of Week — Set to actual day of the week	
	press ■ then ↓ or ↑ press ■	5. Time of Regeneration — Set to desired time of regeneration Note: Time of Regeneration is ignored for Twin-alternating.	
	press ■ then ↓ or ↑ press ■	6. Days Override — Leave at 0 to disable or — Set to desired days override	Max. Days Between Regen: 0 to 99
	press ■ then ↓ or ↑ press ■	7. Salt Dosage — Set to desired dosage lbs per cubic feet of resin	Lbs/ft <sup>3</sup> : 3 to 18 grams/Liter: 50 to 290
	press ↓ to override press ■ then ↓ or ↑ press ■	8. Capacity — Estimated exchange capacity calculated by Logix control — Use to OVERRIDE calculated capacity	Kilograins: 1 to 9999 Kilograms: 0.1 to 999.9
	press ■ then ↓ or ↑ press ■	9. Hardness — Set to actual water hardness	Grains/gal: 3 to 200 Grams/Liter: 30 to 2000

Programming is complete

**Service Display**

Toggles between Capacity Remaining (gallons or m<sup>3</sup>) and Flow Rate (g/m or L/m)  
 In Service LED is On

# 150 Time Clock 742 4-Cycle Conditioner



Screen	Buttons to Press	Description	Range
<p>Time/Day Regeneration Time/Day Salt Amount Capacity</p>	<p>then ↓ or ↑ press ■</p>	<p>1. Valve Type — Select 150 for 4-Cycle Single tank conditioner or — Select 2150 for 4-Cycle Twin-Alternating conditioner</p>	
<p>Time/Day Regeneration Time/Day Salt Amount Capacity</p>	<p>then ↓ or ↑ press ■</p>	<p>2. Resin Volume — Select correct resin volume</p>	<p>Cubic feet: 3.00 to 17.00      Liters: 75 to 500</p>
<p>Time/Day Regeneration Time/Day Salt Amount Capacity</p>	<p>press ■ then ↓ or ↑ press ■</p>	<p>3. Time of Day (12 hr.) — Set to actual time of day Note: Setting includes PM indicator.</p>	
<p>Time/Day Regeneration Time/Day Salt Amount Capacity</p>	<p>press ■ then ↓ or ↑ press ■</p>	<p>4. Day of Week — Set to actual day of the week</p>	
<p>Time/Day Regeneration Time/Day Salt Amount Capacity</p>	<p>press ■ then ↓ or ↑ press ■</p>	<p>5. Time of Regeneration — Set to desired time of regeneration</p>	
<p>Time/Day Regeneration Time/Day Salt Amount Capacity</p>	<p>press ■ then ↓ or ↑ press ■</p>	<p>6. Days Between Regeneration — Set to desired days between regeneration or — Set at 0 to program as a 7-day timer</p>	<p>Days: 0 to 99</p>
<p>Time/Day Regeneration Time/Day Salt Amount Capacity</p>	<p>press ■ then ↓ or ↑ press ■</p>	<p>7. Salt Dosage — Set to desired dosage</p>	<p>Lbs/ft<sup>3</sup>: 3      Grams/Liter: 50 to                    to 18                    290</p>
<p>Time/Day Regeneration Time/Day Salt Amount Capacity</p>	<p>press ↓</p>	<p>8. Estimated Exchange Capacity (view only) — Based on resin volume and salt setting</p>	

**Programming is complete**

**Service Display**

Displays actual day of the week and time of day  
In Service LED is On

# 150 Demand 762F - 3-Cycle Filter



Screen	Buttons to Press	Description	Range
	then ↓ or ↑ press ■	1. Valve Type — Select 153 for 3-Cycle Single tank filter or — Select 2153 for 3-Cycle Twin-Alternating filter	
	press ■	2. Program Type — Select "F"	
	press ■ then ↓ or ↑ press ■	3. Time of Day (12 hr.) — Set to actual time of day Note: Setting includes PM indicator.	
	press ■ then ↓ or ↑ press ■	4. Day of Week — Set to actual day of the week	
	press ■ then ↓ or ↑ press ■	5. Time of Backwash — Set to desired time of backwash Note: Time of Backwash is ignored for Twin-alternating.	
	press ■ then ↓ or ↑ press ■	6. Days Override — Leave at 0 to disable or — Set to desired days override	Max. Days Between Regen: 0 to 99
	press ■ then ↓ or ↑ press ■	7. Backwash Length (minutes) — Set to desired backwash length	Minutes: 1 to 250
	press ■ then ↓ or ↑ press ■	8. Capacity (gallons) — Set to desired capacity in	Gallons: 1      m <sup>3</sup> : 1 x 100      to      to 9999      9999.9

**Programming is complete**

**Service Display**

Toggles between Capacity Remaining (gallons or m<sup>3</sup>) and Flow Rate (g/m or L/m)  
 In Service LED is On

# 150 Time Clock 742F - 3-Cycle Filter



Screen	Buttons to Press	Description	Range
	then ↓ or ↑ press ■	1. Valve Type — Select 153 for 3-Cycle Single tank filter or — Select 2153 for 3-Cycle Twin-Alternating filter	
	press ■	2. Program Type — Select "F"	
	press ■ then ↓ or ↑ press ■	3. Time of Day (12 hr.) — Set to actual time of day Note: Setting includes PM indicator.	
	press ■ then ↓ or ↑ press ■	4. Day of Week — Set to actual day of the week	
	press ■ then ↓ or ↑ press ■	5. Time of Backwash (12 hr) — Set to desired time of backwash	
	press ■ then ↓ or ↑ press ■	6. Days Between Regeneration — Set to desired days between regeneration or — Set to 0 to program as a 7-day timer	Days: 0 to 99
	press ■ then ↓ or ↑ press ■	7. Backwash Length (minutes) — Set to desired backwash length	Minutes: 1 to 250

**Programming is complete**

**Service Display**

Displays actual day of week and time of day.  
In Service LED is On

---

---

## 6.0 Logix Controller

### Power Loss Memory Retention

The Logix series controllers feature battery-free time and date retention during the loss of power. This is designed to last a minimum of 8 hours depending on the installation. The controller will continue to keep time and day in dynamic memory while there is no AC power.

The controller will not track water usage in the event of a power failure.

Information entered or calculated by the controller is stored in two different ways.

A static memory will store:

- Media volume
- Regenerant setting
- Time of regeneration
- Days between regeneration
- Filter mode

A dynamic memory with 8 hour retention will store:

- Current day of week
- Running clock

### Variable Reserve Function

The Logix (762) control is designed to have a variable reserve feature. This feature automatically adjusts the reserve to the end-user's water usage schedule.

Each day the controller reviews the last four weeks of water usage for the same day of the week to determine if the remaining capacity is adequate for the next day. If not, it will initiate an automatic regeneration.

### 6.1 700 Series Initial Power-Up

1. Plug the power cord into a socket that is not controlled by a switch or timer.

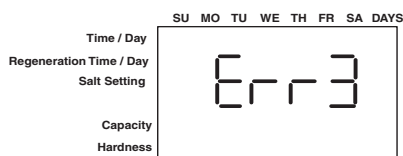

**Caution:** Incorrectly matching the product voltage rating to the main supply will result in damage to equipment.

---

**NOTE:** If "Err3" is displayed, the valve and piston are moving to the service position. This may take up to one minute.

### Initial Programming Instructions

The Logix control can be quickly programmed by using the general information below.

### Valve Type

Your system's OEM may have performed this setting. If so proceed to the next step.



- This setting is used to calibrate the Logix program to the actual valve type. Identification stickers on the Logix control and the valve body show the control and valve type.
- Valve models displayed by the Logix control
  - 150 4-cycle conditioner, single tank
  - 153 3-cycle filter, single tank
  - 2150 4-cycle conditioner, Twin Alternating
  - 2153 3-cycle filter, Twin Alternating

### Program System Size

Your system's OEM manufacturer may have performed this setting. If so, proceed to setting the Time of Day. The system size setting represents the amount of media in the tank.

- Available system sizes:
  - 3 - 15 ft<sup>3</sup> (one ft<sup>3</sup> increments)
  - or
  - 75 - 500 Liters (25 liter increments)
- Select "F" for filter mode.

### 6.2 Level I Parameters

The 700 series controls have Level I Parameters that are quickly programmed by using  or  buttons. Table 1 lists those parameters.

**Table 1: Level I Parameters for 742/762 Controls**

		<b>Parameter Description</b>	<b>Range of Values</b>	<b>Minimum Increment</b>	<b>Default</b>	<b>Units of Measure</b>	<b>Notes</b>
P1		Current Time of Day	1:00 - 12:59 AM or PM 0:00 - 23:59	1 minute	12:00 PM	hour: minute	Range depends on value selected for P10
P2		Current Day of Week	N/A	1 day	None	N/A	Uses arrows under days of week on overlay.
P3		Time of Regeneration	1:00 - 12:59 AM or PM 0:00 - 23:59	1 minute	2:00 AM	hour: minute	Range depends on value selected for P10 Not applicable on twin alternating units or when P16 = 2 or 3.
P4		Calendar Override (Maximum days between regeneration)	0-99	1	3	days	0 = no calendar override, .5 = regeneration twice a day at time of regeneration and 12 hours later. Calendar Override skipped if at least one Day of Regeneration selected. (742 only)
P5		Day of Week Regeneration (Time clock only)	N/A	1 day	None	N/A	Uses bars under days of week on overlay. Day of Week Regeneration is skipped if calendar override is more than zero. See Section 6.3. 742 only.
P6	Conditioner	Salt Setting	3-18 50-290	1 10	9 110	lbs/Ft <sup>3</sup> grams/liter	Unit of measure depends on value in P9
	Filter	Backwash Time (3-cycle filter mode)	0-250	1	14	minutes	Minutes of backwash in 3-cycle filter mode. Uses the arrow that points to salt amount on control in softener mode.
P7	Conditioner	Capacity of unit	1-9999 .1-999.9	1 .1	(1)	kilograins kilograms	Unit of measure depends on value selected for P9. Value is calculated and displayed on 742, but cannot be changed on 742.
	Filter	Capacity of unit (demand only)	100-999,900 1-9999	100 1	(2)	gallons m <sup>3</sup>	Unit of measure depends on value selected for P9.
P8	Conditioner	Hardness of water (demand only)	3-200 30-2000	1 10	25 400	grains per gallon grams per liter	Unit of measure depends on value selected for P9. 762 only.
	Filter	Skipped					
<p>Notes: (1) calculated depending on salt setting and resin volume. (2) Default selected with valve type and resin volume.</p>							

### 6.3 Specific day of week regeneration (7-day timer)

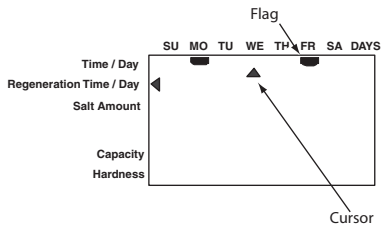

**NOTE:** Regeneration on specific day is used to provide regeneration when water demands are not steady. Example: If the weekdays have low usage and the weekend is high, then regeneration every three days will not meet the requirements.

**NOTE:** Day of week regeneration is only available with 742 controller. 762 controllers do not offer specific day of week regeneration.

To change the 742 controller to regenerate on specific days, set the number of days between regeneration to zero.

After this has been completed, the arrow on the left side of the display will be pointing to Regeneration Time/Day. Press and the display will show a flashing cursor at the top under Sunday. The day of week can be selected when the cursor is below it.

To toggle the day on/off, the triangular cursor must be below that day and flashing.

The or buttons are used to turn the days flag on/off. If the cursor is in position but steady on push to make the cursor flash.

To move the cursor when it is steady on, use the or buttons.

To move the cursor when it is flashing push once. This will move the cursor one position to the right and change the status to steady on.

**Example:** To move the cursor and toggle a day to on/off:

1. The cursor should be steady on. If it is flashing push .
2. Use the or buttons to move the cursor under the day to be changed.
3. Push . The cursor will flash.
4. Use an or button to toggle on the flag for that day.

5. Push to move the cursor to the next day. The cursor will be steady on. When the cursor is under SA (Saturday) and flashing, pushing will complete the days of the week programming. The controller will move to the regenerant amount menu.

To return to days between regeneration, the selected days to regenerate must be turned off. The setting for days between regeneration can then be changed from zero.

The display shown to the left is programmed to regenerate on Monday and Friday.

---

## 7.0 Things You Might Need to Know

- When the controller is first plugged in, it may display a flashing hourglass and the message Err 3, this means that the controller is rotating to the home position. If the Err 2 is displayed, check that the incoming power frequency matches the controller. The North American controller does not run with 50 Hz input.
- The preset default time of regeneration is 2:00 AM.
- English or Metric? The World controller senses the electrical input and decides which is needed. The North American controller only runs on 60 Hz and defaults to English units.
- The Logix 742 Series controller can be programmed to regenerate on specific days of the week.
- The Logix Series controllers send commands to the motor for piston movement. However, water pressure/flow are required during the regeneration cycle for backwash, purge and refill, and brine draw to actually take place.
- Make sure control power source is plugged in. The transformer should be connected to a non-switched power source.
- You can start programming at the beginning by resetting the amount of media. When viewing H0 (History Value) push and hold SET for five seconds. The display reverts back to --- and any programmed information is lost. Return to *Programming Your Control*.

## 8.0 Placing Conditioner Into Operation

1. Make sure to rinse out all debris from piping before connecting the valve.
2. Close inlet, outlet and brine valves.
3. Supply power to timer.
4. Hold the  button on the controller until it indicates that the motor is moving the valve to the backwash position (C1) by flashing an hourglass.
5. Fill the media tank with water.
  - A. While the controller is in cycle C1 (Backwash), open the water supply valve very slowly to approximately the 1/4 open position.



**Caution:** If opened too rapidly or too far, media may be lost out of the tank into the valve or the plumbing. In the 1/4 open position, you should hear air slowly escaping from the valve drain line.

- B. When all of the air has been purged from the media tank (water begins to flow steadily from the drain line), open the main supply valve all of the way. This will purge the final air from the tank.
- C. Allow water to run to drain until the water runs clear from the drain line. This purges any refuse from the media bed.
- D. Turn off the water supply and let the system stand for about five minutes. This will allow for any air trapped to escape from tank.

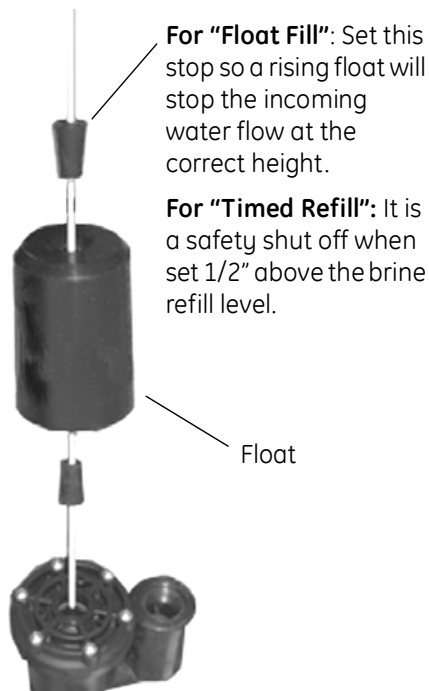

Figure 12

6. Salt dosage:
  - A. Timed refill using brine line solenoid valve:
    - Refill water is set up by opening the solenoid valve for an amount of time that will allow the desired volume of water to go into the brine tank at the selected refill flow rate.
    - The float valve is used to prevent overflow. It has to be set at a height above brine refill level. See Figure 12.

### US Example:

10 ft<sup>3</sup> of resin at 9 lbs of salt/ft<sup>3</sup> of resin

Refill water -  $(10 \times 9)/3 = 30$  gallons of water

If Refill Flow Rate = 3 gpm

Program Refill Time (C8) at 10 minutes

**NOTE:** Brine line is normally pressurized. A solenoid valve must be used in brine line for timed brine refill. Use auxiliary relay output to control brine solenoid.

- B. Float fill with brine line valve:
  - Calculate volume of water for desired salt dosage. 1 gallon of water dissolves 3 lbs of NaCl, or 1 liter of water dissolves 0.36 kilograms of NaCl

### US Example:

10 ft<sup>3</sup> of resin at 9 lbs of salt/ft<sup>3</sup> of resin

Refill water =  $(10 \times 9)/3 = 30$  gallons of water

### Metric Example:

283 liters of resin at 144 grams of NaCl/liter of resin

Refill water =  $(283 \times 144)/360 = 113$  liters of water





- Install the air check at a height above the tank bottom that will ensure that the volume of refill water (30 gallons based on US Example) will go 1/2-inch or more above the salt grid.
  - Fill brine tank with water up to the air check level.
  - Add calculated volume of water (30 gallons based on US example) to brine tank. Close brine line valve and remove power to the Logix timer.
  - Load brine tank with salt. Water level will go higher. Mark tank water level and set up float to close refill at that height. Salt needs to cover water at all times. See Figure 13.
  - Open brine line valve again.
  - The concentrated brine will expand and the level will rise, but the dosage will remain the same.
7. Power the Logix timer and advance the valve to the draw and slow rinse position (C2). Check the flow rate at the drain port. It should be equal to the installed injector's total flow at the inlet pressure (see Injector Charts). Hold the unit in this position for three minutes and observe that the water level in the brine tank is going down.





## 9.0 Regeneration Modes

The 700 Series controllers can be regenerated either automatically or manually. During a regeneration, the total time remaining of the regeneration is displayed on the controller. The current cycle is shown in the lower left of the display.

"Keys" are listed as:

-  UP for up arrow
-  DOWN for down arrow
-  SET for set
-  REGEN for regeneration

### Manual Regeneration:

**Delayed Manual Regeneration** — Pressing the  key programs a delayed manual regeneration. The regeneration icon on the LCD flashes indicating that a regeneration starts when the time of day reaches the programmed time of regeneration. Pressing the  key again turns off the regeneration icon and cancels the delayed regeneration.

**Immediate Manual Regeneration** — Pressing and holding the  key for three seconds initiates an immediate manual regeneration. The regeneration icon on the LCD turns on. The control goes to the regenerating mode.

**Delayed Second Regeneration** — Pressing the  key while the control is in the regenerating mode programs a delayed second regeneration. The x2 icon next to the regeneration icon flashes indicating a second regeneration starts when the time of day reaches the programmed time of regeneration.

**Double Immediate Manual Regeneration** — Pressing and holding the  key for three seconds while the control is in the regenerating mode programs back-to-back manual regenerations. The x2 icon next to the regeneration icon turns on indicating a second manual regeneration starts immediately after the current regeneration is complete.

### During a Regeneration:



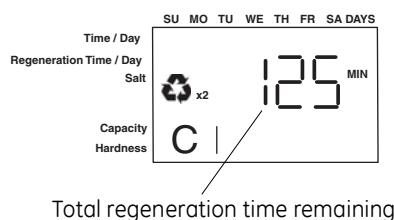

- A "C#" is displayed to show current cycle.





- Total regen time remaining is displayed on screen.

- Press and hold  to show current cycle time remaining.

### To Advance Regeneration Cycles:

- Simultaneously press  and  to advance one cycle. An hourglass displays while the cam is advancing.
- Repeat  and  to advance through each cycle.

### To Cancel Regeneration:

- Press and hold  and  for 5 seconds to cancel regen. Hourglass flashes once cancelled. Motor advances the cam to home – may take 1 to 2 minutes.

**NOTE:** If a second regeneration was programmed, each regeneration must be canceled separately.

**NOTE:** Canceling a regeneration may cause undesirable or salty water to go into service. Use only when necessary.

### Regeneration Cycles:

- C1 – Backwash
- C2 – Regeneration Draw/Slow Rinse (not used in filter mode)
- C3 – Slow Rinse (not used in filter mode)
- C5 – Fast Rinse cycle
- C8 – Regenerant Refill (not used in filter mode)

---

---

## 9.1 Remote Regeneration — Dry Contact Input

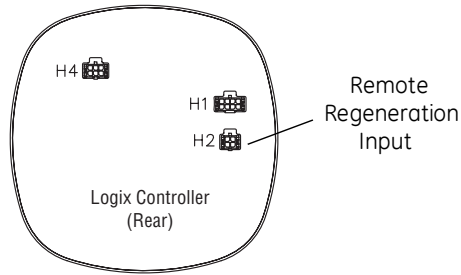

The 742 controller has a remote regeneration input that is activated by a dry-contact closure signal from a variety of devices. These devices could be: a PLC controller, a filter pressure differential ( $\Delta P$ ) switch, a manual switch button, another water treatment device controller, or an independent timer.

This feature is automatically enabled on all 742 controllers. The Logix controller remote regen input cable harness, is used to connect to the controller. See Figure 16.



**Caution:** Use of non water-tight fittings will degrade the water tight integrity of this product and could result in damage to equipment and/or harm to personnel.

---

**NOTE:** Remote regeneration is not available on 762 controllers.

**NOTE:** If the dry contact signal is not removed at the completion of the regeneration, the controller will initiate another regeneration once the P12 value times out.

A regeneration will begin when a dry contact closure signal is input into the controller for the amount of time programmed in P12. The controller will follow a normal regeneration sequence as was programmed by the installer. Any further signals from the dry contact are ignored during regeneration.

To use the dry contact closure as the only means for initiating regeneration, set the "Calendar Override" (P4) to 0 and do not enable any days of the week (P5) for regeneration. This will cause the controller to regenerate only when remotely signaled.

The controller will also operate with a combination of the remote regeneration signal, and programmed regeneration days.

## 10.0 Programming the Logix for Manganese Greensand Systems

### Manganese Greensand Systems

#### Sizing 5-Cycle Filters

Potassium permanganate regenerating iron filters should be sized for the appropriate backwash and injector sizes.

#### Backwash Controller

Be sure to choose the appropriate backwash flow rate control (see *Parts* section) as recommended by your media manufacturer.

#### Injector

Use the same injector size as you would for your conditioner control tank diameter.

#### Refill Controller

The refill flow rate is controlled by the injector. Use a float valve in your potassium permanganate feeder to set potassium permanganate dosage.

#### Initial Resin Volume Setting

Programming for a manganese greensand system requires a few minor adjustments to the programming to operate the control correctly. The initial resin volume should be set to the closest volume of the manganese greensand in the system. For example, if the system contains four cubic feet of manganese greensand, program in 4.00 for the resin volume.

#### "Salt" Setting for $KMNO_4$ Regenerant

Be sure to set the salt dosage high enough to operate the float shut-off in the regenerant storage tank.

All other settings remain the same as mentioned in the previous programming sections.

#### Days Between Regeneration Setting (742)

To set the days between regenerations, consult the media manufacturer for the actual capacity of the media.

In general, manganese greensand has a capacity of 10,000 ppm of removal capability per cubic foot of media. Calculate the capacity of the system by taking the number of cubic feet of media and multiply by 10,000.

For example, using a 1 cubic foot system provides 10,000 ppm of removal capability.

The next step is to calculate the demand for the system. Multiply the predicted daily water usage by the iron content in ppm.

For example, an average person uses 75 gallons of water per day. Four people living in a home use 300 gallons of water (75 gallons x 4 people) per day. Assume the incoming water has 10 ppm of iron. Now calculate the daily demand: multiply the gallons of water used per day (300) by the ppm of iron content (10) = 3000 ppm of daily capacity usage.

Now take the system capacity (10,000), divided by the daily demand (3,000) = 3.3 days of capacity. Since you run out of capacity before the beginning of the fourth day, the proper setting for days between regeneration is 3 days.

For example:

$$4 \text{ people} \times 75 \text{ gals per person} = 300 \text{ gallons used per day.}$$

$$10 \text{ ppm iron} \times 300 \text{ gal/day} = 3000 \text{ ppm/day}$$

$$10,000 \text{ ppm capacity} \div 3000 \text{ ppm/day} = 3.3 \text{ days of total capacity}$$

Solution = regenerate every 3 days.

The above capacity numbers are based only on Fe. For removal of  $H_2S$  and Mn refer to the media manufacturers specifications.

#### Volume/Demand Regeneration Setting (762)

To set a 762 demand system for iron removal you must:

1. Know your media capacity. Generally, one cubic foot of magnesium greensand can remove 10,000 ppm of iron.
2. Know the iron concentration in your water.

To have your system regenerate on demand, set your system's capacity (P7) to the appropriate factor. On the 762, it reads Kg, but you are actually working in ppm of iron.

1. If your system is one cubic foot, set the capacity to "10" kg, meaning 10,000. For two cubic feet, set the capacity to "20" kg.

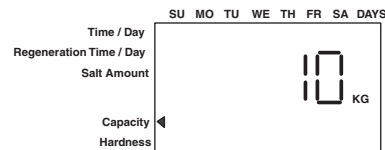

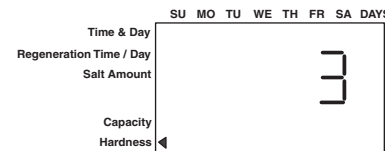

2. Set your hardness to the level of ppm iron in your water. If you have 3 ppm of iron, set the 762 control to "3".



3. The control calculates the remaining volume capacity in gallons ( $m^3$ ) and counts down to regeneration.

## 11.0 Level II Programming

The 742/762 features a special programming level for more demanding applications. The home owner/end user should never have to access this level.

To enter Level II programming press and hold  and  for 5 seconds. A "P" value is displayed indicating Level II.

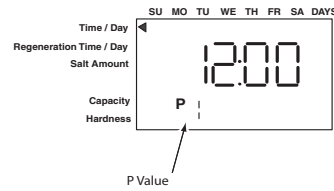

**Table 2 Level II Parameters for 742/762**

	Parameter Description	Range of Values	Minimum Increment	Default	Units of Measure	Notes
P9	Units of measure	0-1	1	(2)		0 = US, 1 = Metric
P10	Clock mode	0-1	1	(2)		0 = 12 hour clock, 1 = 24 hour clock
P11	Service Interval	0-250	1	0	months	Uses 30 days for each month.
P12	Remote Regeneration Switch Delay (Time clock only)	3-250	1	60	seconds	Time remote switch must be active to start regeneration (742 only).
P13	Skipped					
P14	Conditioner	Refill rate	0-400	1	(1)	gpm x 100
	Filter	Skipped				
P15	Conditioner	Draw rate	0-400	1	(1)	gpm x 100
	Filter	Skipped				
P16 (3)	Reserve Type (demand only)	0-3	1	0		0 = Variable reserve delayed regeneration 1 = Fixed reserve delayed regeneration 2 = Variable reserve immediate regeneration 3 = Fixed reserve immediate regeneration
P17 (3)	Initial average or fixed reserve (demand only)	0-70	1	30	% of Capacity	Depends on value entered in P16
P18 (3)	Flow sensor select (demand only)	1-4	1	(1)		1=1" Autotrol turbine, 2=2" Autotrol turbine, 3=User defined K-Factor, 4=User defined Pulse Equivalent,
P19 (3)	K-Factor or Pulse Equivalent (demand only)	0.01-99.99 1-9999	0.01 1	0.01 1	ppg gpp	K-Factor P18=3; Pulse Equivalent P18-4

Notes: (1) default selected with valve type and resin volume. (2) Factory Default is "0" for North America units and "1" for World Units. (3) P16 through P19 skipped on 742 time clock units.

## 11.1 Locking/Unlocking Parameters

Level I parameters 1 thru 8 can be locked/unlocked during Level II programming. When the Level I P number is displayed, pushing  will toggle the lock.

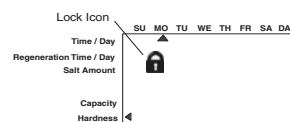



## 11.2 Explanation of Level II Parameters

Parameter	Parameter Description	Explanation
P9	Units of Measure	Enter 0 for US units; enter 1 for Metric units
P10	Clock Mode	Enter 0 for 12-hour clock; enter 1 for 24-hour clock
P11	Service Interval	Enter desired amount of time, in months, before the maintenance required symbol is displayed. Enter 0 to never display maintenance required system. See Section 13.1 for more information.
P12	Remote Regeneration Switch Delay (Time clock only)	Enter the amount of remote signal time, in seconds, required to initiate a remote regeneration. A counter starts when there is a closed dry contact (no voltage) and a regeneration will begin when the contact remains closed for the programmed time. The counter will reset to zero if the contact opens. Remote regeneration only available on the 742, not available on 762. See Section 9.1 for more information.
P13	Skipped	
P14	Refill Rate	Enter the refill flow rate in gallons per minute times 10. If no external refill flow control is used, the injector and pressure determine the refill rate. For example, with a 150-A (yellow) injector the refill rate at 40 psi is 3.8 gpm. Calculate: 3.8 gpm $\times$ 10 = 38. Enter 38 for this example. See Section 17.2 for refill rates at various pressures. Because the brine line is normally pressurized, this parameter typically only applies if a solenoid operated brine valve is used. Default values are typically acceptable (conditioners only).
P15	Draw Rate	Enter the regenerant draw rate in gallons per minute times 10. For example, with a 150-A (yellow) injector at 40 psi the draw rate is 0.7 gpm. Calculate: 0.7 gpm $\times$ 10 = 7. Enter 7 for this example. See Section 17.2 for draw rates at various pressures. Default values are typically acceptable (conditioners only).
P16	Reserve Type (Demand only)	0 = Variable reserve delayed regeneration. The unit will check at the P2 time to see if the variable reserve capacity based on prior usage has been reached. If it has the unit will regenerate at the P2 time. 1 = Fixed reserve delayed regeneration. The unit will check at the P2 time to see if the fixed reserve, P17, has been reached. If it has the unit will regenerate at the P2 time. 2 = Variable reserve immediate regeneration. Same as 0 except unit will also regenerate at any time the capacity reaches zero regardless of the time of day. 3 = Fixed reserve immediate regeneration. Same as 1 except unit will also regenerate at any time the capacity reaches zero regardless of the time of day. Note: Ignored in twin alternating mode.
P17	Initial average or fixed reserve (Demand only)	Enter the desired initial or fixed reserve as percentage of capacity. Note: Ignored in twin alternating mode.
P18	Flow Sensor Select (Demand only)	Enter 1 for 1" Autotrol turbine; enter 2 for 2" Autotrol turbine; enter 3 for user defined K-Factor; enter 4 for user defined pulse equivalent.
P19	K-Factor or Pulse Equivalent (Demand only)	Enter K-Factor if P18 = 3 or pulse equivalent if P18 = 4 for meter being used. Consult flow meter manufacturer for proper K-Factor or pulse equivalent value.



## 12.0 Cycle Time Programming

The 742 and 762 controls allow users to program all cycle times manually. Use this feature to view or enter user-defined cycle times.

### To View Cycle Times:

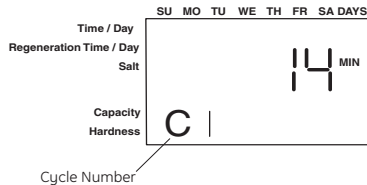
- View programmed cycle time by holding  AND  for 5 seconds.



- Use  or  to display programmed time in each cycle.

**Table 3 Cycle Times**

Cycle	Default Cycle Time (minutes)	Cycle Time Range (minutes)
C1- Backwash	14	0-250
C2- Draw (1)	(2)	
C3 - Slow Rinse	(3)	
C5 - Fast Rinse	6	
C8- Refill (1)	(4)	

(1) Draw and Refill times are calculated on a conditioner valve using the draw, refill rates and salt setting. Draw and Refill times may be programmed in minutes on the 3 cycle filter valve.

(2) Depends on valve type and resin volume. Time calculated from total salt amount and draw rate.





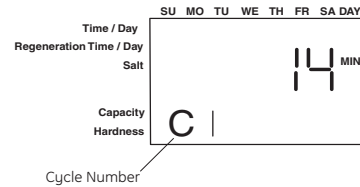

(3) Depends on valve type, resin volume, and rinse rate. Time calculated for 2.0 bed volumes.

(4) Depends on valve type and resin volume. Time calculated from total salt amount and refill rate.

### To Program Individual Cycle Times:

- Hold  AND  to enter cycle time programming mode.



- Press  or  to select cycle to be changed.
- Press  while a programmed cycle time is displayed. The cycle time in minutes flashes, indicating it can be changed.
- Press  or  to change the flashing cycle time.
- Press  to enter the flashing time displayed for that cycle.
- Repeat procedure to program other cycle times.

## 12.1 Auxiliary Relay Programming

Two auxiliary relay outputs “A” and “b” are available and can be programmed to meet user needs. Each auxiliary

relay output can be programmed to be energized during all or part of each cycle individually. See Figure 17 for wiring.

### Setting the Auxiliary Outputs

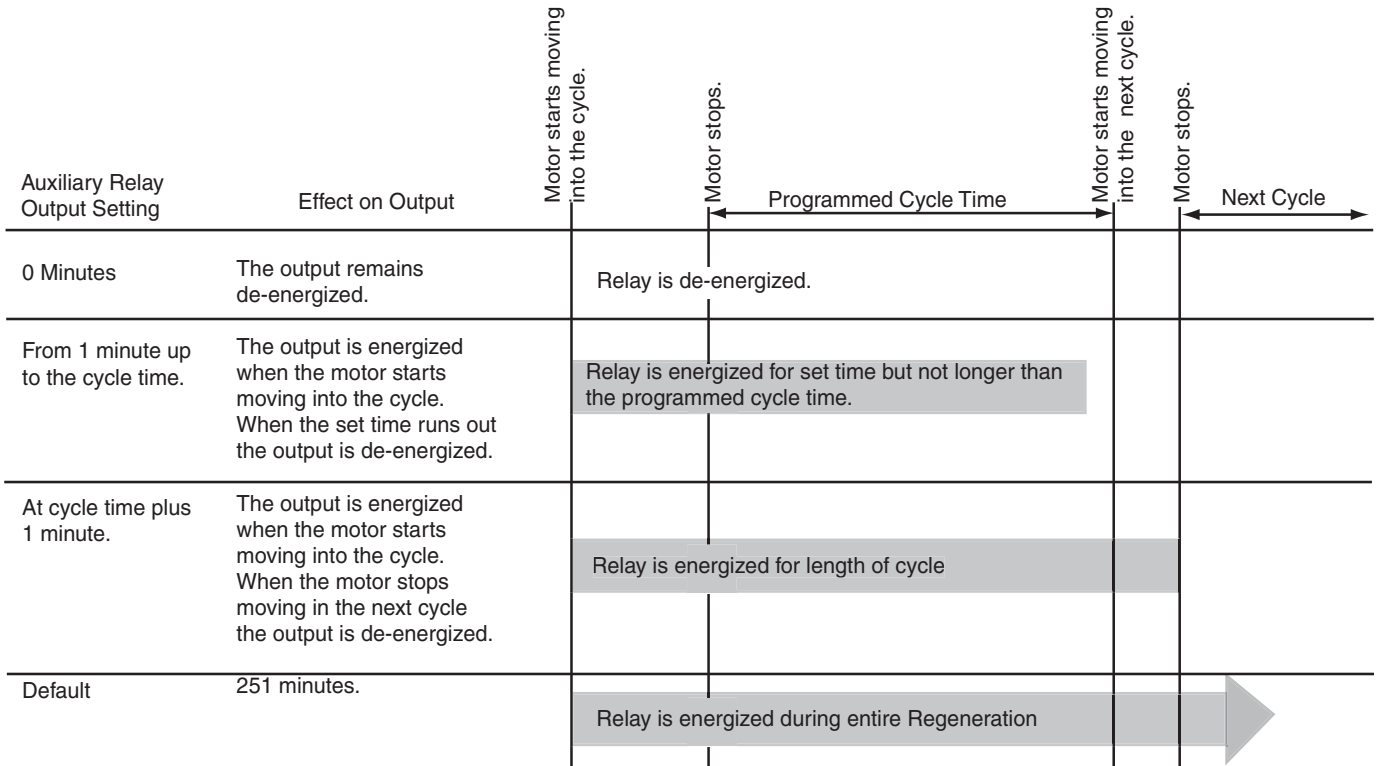

### To View Auxiliary Relay Times:

**NOTE:** Auxiliary relays are not programmable on twin alternating systems.

1. Enter cycle time programming by holding AND for 5 seconds.

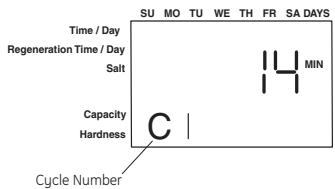

2. Press to enter auxiliary output programming mode. The letter “A” or “b” is shown in the left-most digit of the display, indicating the auxiliary output is being displayed.

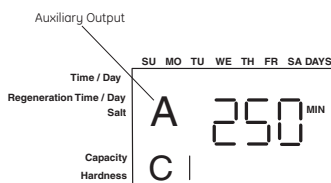



3. Press or to display auxiliary output times for each cycle.
4. Press again to toggle between cycle time programming, auxiliary output “A” programming and auxiliary output “b” programming.

### To Program Auxiliary Relay Output Times:

1. Press while the auxiliary relay output time is displayed. The auxiliary output time flashes indicating it can be changed.
2. Press or to change the flashing time displayed for that cycle.
3. Press to enter the flashing time displayed for that cycle.
4. Repeat procedure to program other auxiliary relay output times.

## 13.0 Accessing History Values

The 742/762 features a review level that displays the operation history of the system. This is a great troubleshooting tool for the control valve.

To access history values, hold  and  for five seconds to view the "H" levels.

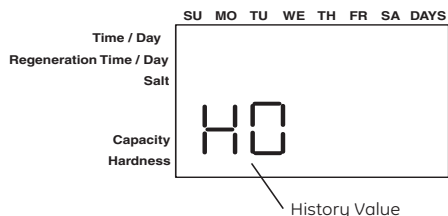

**Table 4 History Values**

	Description	Range	Notes
H0 <sup>a</sup>	Initial setting value	Cubic feet or liters	Resin volume
H1	Days since last regeneration	0 - 255	
H2	Current flow rate	0 - 200 gpm or 0 - 757 Lpm	762 only
H3	Water used today in gallons/m <sup>3</sup> since Time of Regeneration	0 - 1,300,000 gallons or 0 - 13,107 m <sup>3</sup>	762 only
H4	Water used since last regeneration in gallons/m <sup>3</sup>	0 - 1,300,000 gallons or 0 - 13,107 m <sup>3</sup>	762 only
H5 <sup>a</sup>	Total water used since reset in 100s	0 - 999,900 gallons or 0 - 9,999 m <sup>3</sup>	762 only
H6 <sup>a</sup>	Total water used since reset in 1,000,000	4,294 x 10 <sup>6</sup> gal or 4,264 x 10 <sup>4</sup> m <sup>3</sup>	762 only
H7	Average usage for Sunday in gallons or m <sup>3</sup>	0 - 1,300,000 gallons or 0 - 13,107 m <sup>3</sup>	762 only
H8	Average usage for Monday in gallons or m <sup>3</sup>	0 - 1,300,000 gallons or 0 - 13,107 m <sup>3</sup>	762 only
H9	Average usage for Tuesday in gallons or m <sup>3</sup>	0 - 1,300,000 gallons or 0 - 13,107 m <sup>3</sup>	762 only
H10	Average usage for Wednesday in gallons or m <sup>3</sup>	0 - 1,300,000 gallons or 0 - 13,107 m <sup>3</sup>	762 only
H11	Average usage for Thursday in gallons or m <sup>3</sup>	0 - 1,300,000 gallons or 0 - 13,107 m <sup>3</sup>	762 only
H12	Average usage for Friday in gallons or m <sup>3</sup>	0 - 1,300,000 gallons or 0 - 13,107 m <sup>3</sup>	762 only
H13	Average usage for Saturday in gallons or m <sup>3</sup>	0 - 1,300,000 gallons or 0 - 13,107 m <sup>3</sup>	762 only
H14	Average service cycle	0 - 255 days	762 only
H15 <sup>a</sup>	Peak flow rate	0 - 200 gpm or 1,000 Lpm	762 only
H16	Day and time of peak flow rate	Time and day that peak flow occurred	762 only
H17 <sup>a</sup>	Months since service	0 - 2,184 months	

a. H0, H5, H6, H15, H17 values can be reset by pressing and holding  for 3 seconds while the values are being displayed.





---

## 13.1 Maintenance Interval

The history value P11 may be set to a predetermined interval. The interval (in months) would be determined by a desired maintenance event. When the value for P11 is reached, the display will show



To reset the maintenance interval and clear the display:

1. Access history values by holding  AND  for 5 seconds.
2. Use  or  to show H17.
3. Hold  for 3 seconds while H17 is displayed.





---

---

## 14.0 Control Reset

**NOTE:** Resetting the control deletes all information stored in its memory, except time and day. This requires you to reprogram the control completely from the initial power-up mode.

To reset the control back to its original unprogrammed state:

1. Hold  AND  simultaneously for 5 seconds.
2. H0 and the system's set resin volume (or "F" mode) is displayed.
3. If a history value other the "H0" is displayed, use the  button to scroll through the settings until "H0" is displayed.
4. To reset the control, hold  for 5 seconds.
5. The display will show a flashing "150" indicating it is reset to an unprogrammed state.
6. Go to "Initial Set-up" section to reprogram control.

# 15.0 Electrical Drawings

## Flow Sensor Connections

The 762 control may be connected to a number of different flow sensing devices. Figure 14 shows the connections for the Autotrol turbine type flow sensor. Figure 15 shows the connections for the Signet flow sensor.

**NOTE:** The 762 may also be used with two-wire "Contacting Head" meters (Pulse Equivalent, P19 set to a 4) by connecting the meter leads as shown in Figure 16.

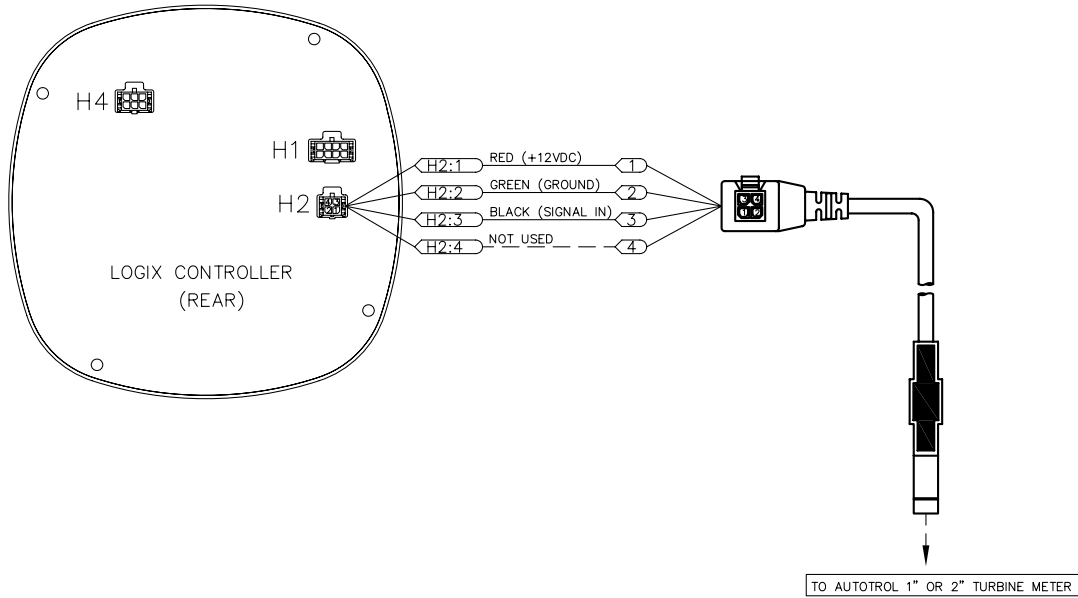

Figure 14 Autotrol Meter

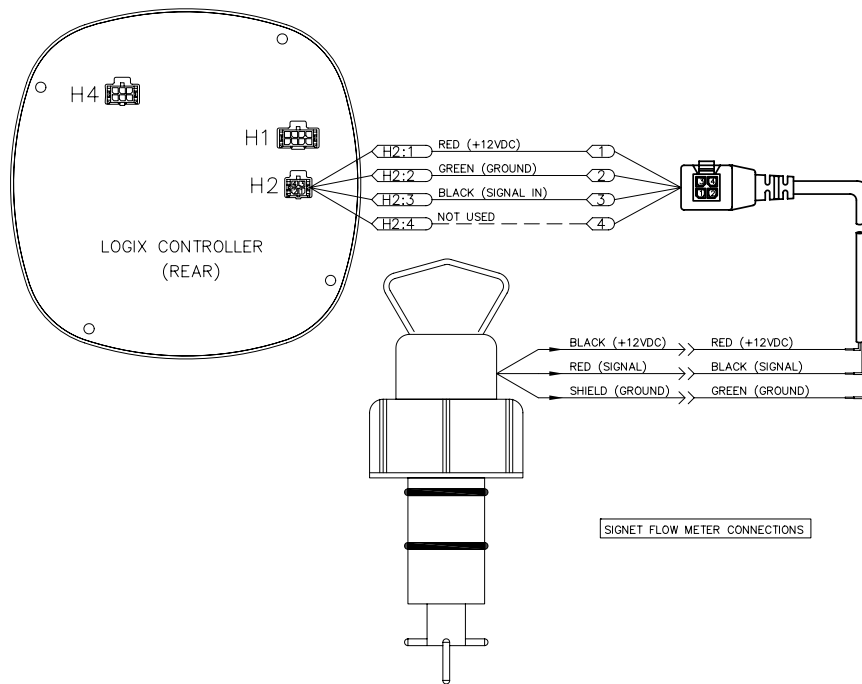

Figure 15 Signet Flow Sensor

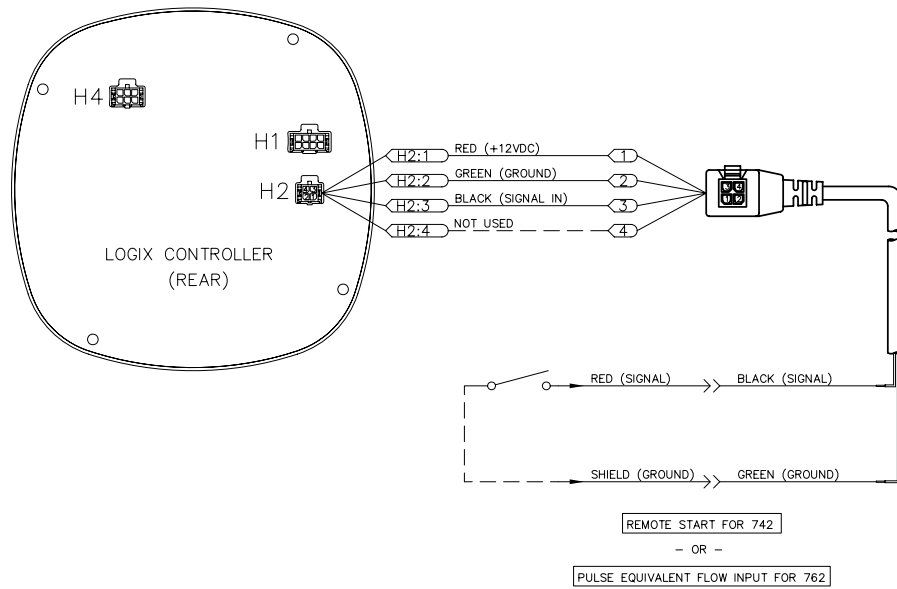

Figure 16 Remote Start / Pulse Equivalent Flow Input

If the meter is not the Autotrol Turbine Meter the provided turbine cable assembly must be modified.

- Cut off the autotrol turbine sensor.
- Modify the wires to suit your meter type.



**Caution:** Use of non water-tight fittings will degrade the water tight integrity of this product and could result in damage to equipment and/or harm to personnel.

**WARNING**



TO AVOID RISK OF ELECTRICAL SHOCK, A VALID ELECTRICAL EARTH GROUND MUST BE CONNECTED TO THE GROUND LUG PROVIDED ON THE VALVE MOTOR PLATE.

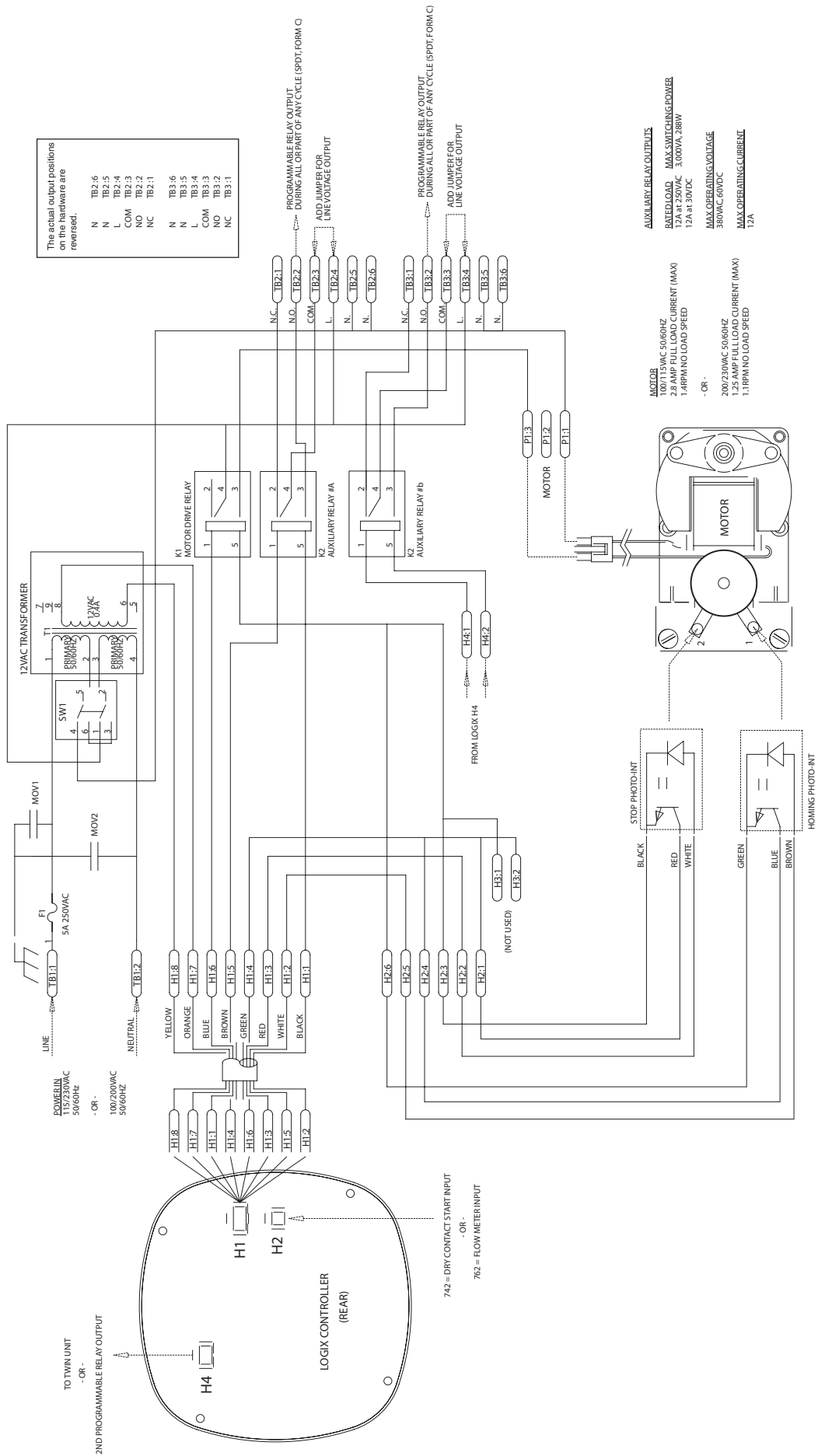

The actual output positions on the hardware are reversed.

N	TB2.6
N	TB2.5
L	TB2.4
COM	TB2.3
NO	TB2.2
NC	TB2.1
N	TB3.6
N	TB3.5
L	TB3.4
COM	TB3.3
NO	TB3.2
NC	TB3.1

**AUXILIARY RELAY OUTPUTS**  
**RATED LOAD - MAX SWITCHING POWER**  
 12A @ 250VAC 3.000VA-288W  
 12A @ 30VDC  
**MAX OPERATING VOLTAGE**  
 380VAC 60VDC  
**MAX OPERATING CURRENT**  
 12A

**MOTOR**  
 100/115VAC 50/60HZ  
 2.8 AMP FULL LOAD CURRENT (MAX)  
 1.4HP@NO LOAD SPEED  
 -OR-  
 200/230VAC 50/60HZ  
 1.25 AMP FULL LOAD CURRENT (MAX)  
 1.1HP@NO LOAD SPEED

Figure 21 Single Unit

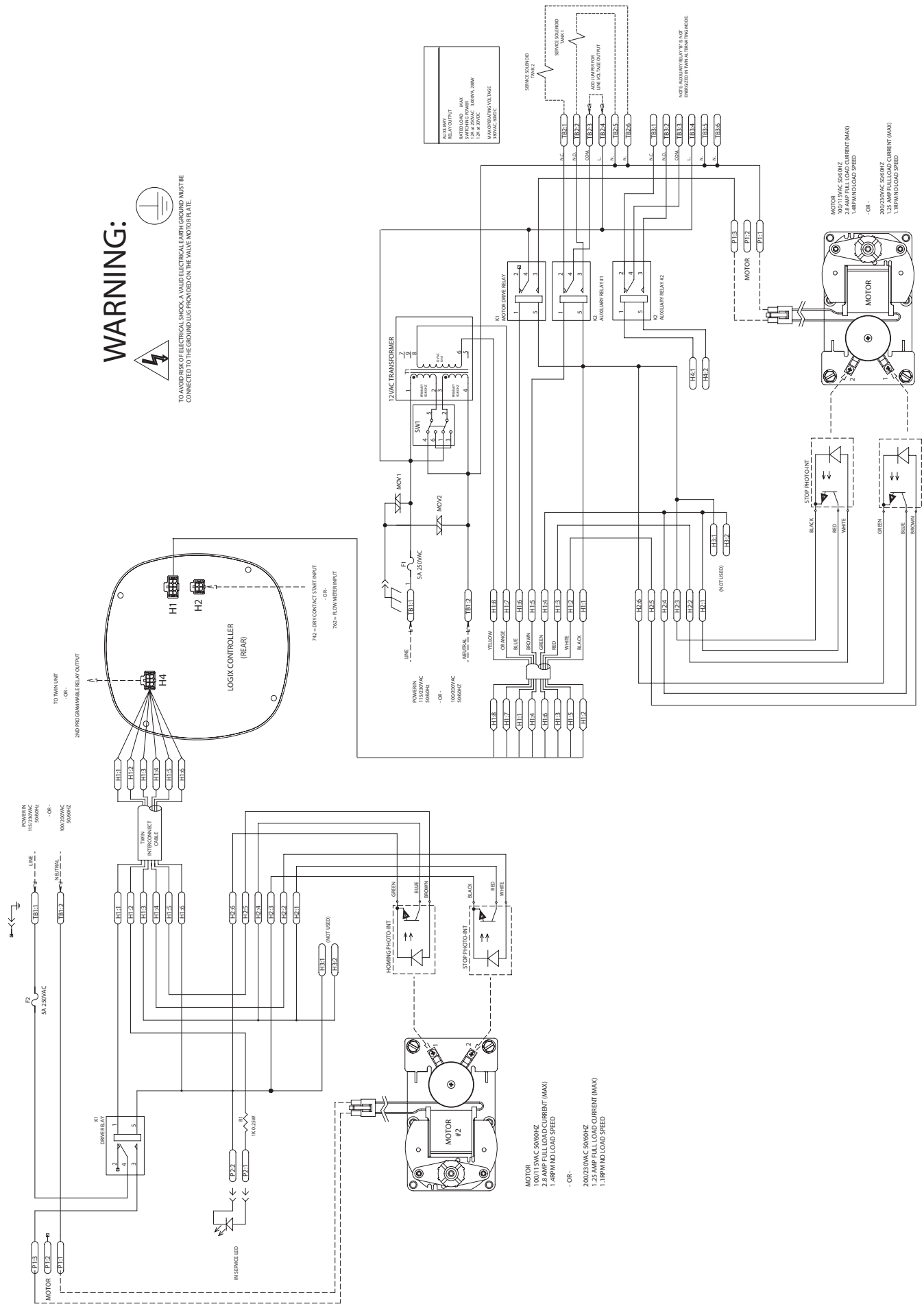

**WARNING:**



TO AVOID RISK OF ELECTRICAL SHOCK, A VALID ELECTRICAL GROUNDING SYSTEM MUST BE CONNECTED TO THE GROUND LUG PROVIDED ON THE VALVE MOTOR LATE.

Figure 22 Twin Alternating System

## 16.0 Troubleshooting

### 16.1 Troubleshooting: Logix Controller

Problem	Possible Cause	Solution
ERR 1 is displayed	Controller power has been connected and the control is not sure of the state of the operation.	Press the UP arrow and the control should reset.
ERR 2 is displayed	Controller power does not match 50 or 60 Hz.	Disconnect and reconnect the power. If problem persists, obtain the appropriate controller or AC adapter for either 50 or 60 Hz power.
ERR 3 is displayed	Controller does not know the position of the cam. Cam should be rotating to find Home position.	Wait for two minutes for the controller to return to Home position. The hourglass should be flashing on the display indicating the motor is running.
	Motor thermal protection cutoff has stopped motor.	Allow motor to cool. Check for and clear any debris which restricts piston movement.
	Cam is not turning during ERR 3 display.	Check that motor is connected. Verify that motor wire harness is connected to motor and controller module. Verify that optical sensors are connected and in place. Verify that motor gear has engaged cam gear. If everything is connected, try replacing in this order: <ul style="list-style-type: none"> <li>—Optical sensor</li> <li>—Controller</li> <li>—Motor</li> </ul>
	Unit programmed as twin alternating, but interconnect cable is not connected.	Check system model setting. If a twin alternating model is selected (2150 or 2153) check interconnect cable connections. If a single tank or parallel flow system, assure proper model is selected (150 or 153).
Four dashes displayed: — : — —	Power failure of more than 8 hours has occurred	Press SET to reset the time display.

## 16.2 Troubleshooting: 150 Valve

Problem	Possible Cause	Solution
<p>No soft water OR Water conditioner fails to regenerate.</p>	<ul style="list-style-type: none"> <li>a. Manual bypass valve is open .</li> <li>b. Power supply interruption.</li> <li>c. Blown fuse.</li> <li>d. Water pressure lost.</li> <li>e. Insufficient brine .</li> <li>f. No salt in brine tank.</li> <li>g. Control improperly programmed.</li> <li>h. If a metered unit, flow meter not connected to control.</li> <li>i. If a metered unit, flow meter is clogged or restricted.</li> <li>j. Leak at riser pipe seal.</li> <li>k. Plugged injector or injector screen.</li> <li>l. Salt bridging.</li> <li>m. Brine line shut off valve closed.</li> <li>n. Cross connection in service line .</li> <li>o. Brine director malfunctioning on multiple tank systems sharing a brine tank.</li> </ul>	<ul style="list-style-type: none"> <li>a. Close manual bypass valve.</li> <li>b. Determine reason for power interruption and correct. Reset time of day if required.</li> <li>c. Replace blown fuse. Correct cause of excessive current draw. Reset time of day if required.</li> <li>d. Restore water pressure.</li> <li>e. Check brine float setting. Check flow rate capabilities of brine float and air check assembly .</li> <li>f. Add salt and regenerate .</li> <li>g. Reset control and reprogram.</li> <li>h. Connect flow meter to control.</li> <li>i. Inspect flow meter. Clean and replace as necessary.</li> <li>j. Ensure riser pipe is properly sealed at tank adapter O-ring. Inspect riser pipe for cracks.</li> <li>k. Inspect and clean injector and/or injector screen.</li> <li>l. Break salt bridge and regenerate.</li> <li>m. Open brine line shut off valve.</li> <li>n. Check service line and eliminate cross connections .</li> <li>o. Check brine director for proper operation.</li> </ul>
<p>Poor water quality. OR Reduced capacity of soft water.</p>	<ul style="list-style-type: none"> <li>a. Inlet water quality has changed.</li> <li>b. Loss of media to drain due to improper backwash flow.</li> <li>c. Loss of media to drain due to gasses in system.</li> <li>d. Leak at riser pipe seal.</li> <li>e. Leak past piston seal # 1.</li> <li>f. Improper piston seal location within valve.</li> <li>g. Fouled resin.</li> <li>h. Improper regeneration settings.</li> <li>i. Media channeling.</li> </ul>	<ul style="list-style-type: none"> <li>a. Check inlet quality and adjust appropriately.</li> <li>b. Install proper drain line flow restrictor.</li> <li>c. Ensure excessive gasses are not present in feed water. Ensure brine line fittings are tight and that air check closes.</li> <li>d. Ensure riser pipe is properly sealed at tank adapter o-ring. Inspect riser pipe for cracks.</li> <li>e. Remove piston through drain side of valve. Inspect seals and replace piston as necessary.</li> <li>f. Ensure cam engages with motor and optical sensors functioning properly. Ensure drive link assembly is engaged with piston.</li> <li>g. Inspect and change it if needed. Eliminate fouling cause.</li> <li>h. Check control settings and adjust as required.</li> <li>i. Ensure proper backwash flow rate and time and regenerate system. Inspect and repair distributors. Maintain minimum flow rates.</li> </ul>

<p>Insufficient brine draw OR Salty water to service</p>	<ul style="list-style-type: none"> <li>a. Clogged injector or injector screen.</li> <li>b. Injector is too small for system size.</li> <li>c. Restriction in brine line.</li> <li>d. Insufficient water pressure.</li> <li>e. Obstructed drain line.</li> <li>f. Excessive back pressure on injector due to drain line restriction.</li> <li>g. Brine line pulling air.</li> <li>h. Premature checking of brine float.</li> <li>i. Piston seal #1 damaged.</li> <li>j. Insufficient draw/slow rinse time.</li> </ul>	<ul style="list-style-type: none"> <li>a. Inspect and clean injector and/or injector screen.</li> <li>b. Install proper size injector .</li> <li>c. Find and clear restriction in brine line. Check flow rate capabilities of the air check assembly. Ensure brine shut off valve is fully open.</li> <li>d. Increase water pressure.</li> <li>e. Remove obstruction.</li> <li>f. Reduce drain line elevation or shorten total length of drain line.</li> <li>g. Ensure all brine line fittings are air tight.</li> <li>h. Install appropriate size flow control in brine line or change brine float.</li> <li>i. Remove piston, inspect for debris and damage. Clean valve and replace piston if required.</li> <li>j. Check control settings and adjust as required.</li> </ul>
<p>Excessive water in brine tank</p>	<ul style="list-style-type: none"> <li>a. Improper brine float setting.</li> <li>b. Programmed salt setting does not determine amount of water in brine tank – the brine line is normally pressurized.</li> </ul>	<ul style="list-style-type: none"> <li>a. Set brine float to proper height.</li> <li>b. Set brine float to desired setting.</li> </ul>
<p>Mineral to service</p>	<ul style="list-style-type: none"> <li>a. Side Mount, missing or damaged bottom distributor.</li> <li>b. Side Mount, unit installed backwards.</li> <li>c. Top Mount, damaged or broken bottom distributor caused by loading media. Hot water is backing into unit. The riser is too long .</li> </ul>	<ul style="list-style-type: none"> <li>a. Remove plug at the tank bottom, finding mineral and gravel confirms cause. Fix distributor.</li> <li>b. See markings on valve for proper orientation and correct if necessary.</li> <li>c. Inspect and replace distributor. Provide a layer of water above distributor to cushion impact of media, install check valve on service line if required, and cut riser ¼" below tank top.</li> </ul>
<p>Leak to drain</p>	<ul style="list-style-type: none"> <li>a. Piston seal #3 damaged.</li> </ul>	<ul style="list-style-type: none"> <li>a. Remove piston, inspect for debris and damage. Clean valve and replace piston if required.</li> </ul>
<p>Increased pressure drop</p>	<ul style="list-style-type: none"> <li>a. Fouled or damaged media.</li> <li>b. Plugged collectors or distributors.</li> <li>c. Excessive fines in media due to inadequate backwash.</li> </ul>	<ul style="list-style-type: none"> <li>a. Evaluate and correct cause of media damage.</li> <li>b. Inspect and replace collectors or distributors. Find and correct cause of plugging.</li> <li>c. Ensure appropriate backwash flow rates are obtained for system size. Adjust backwash time as required.</li> </ul>

## 16.2 Flow Diagrams

### 1 Service Position

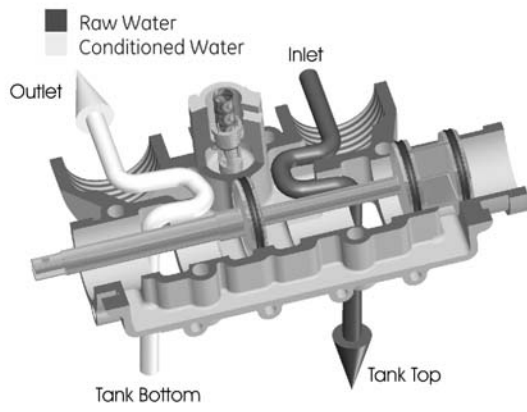

### 2 Backwash

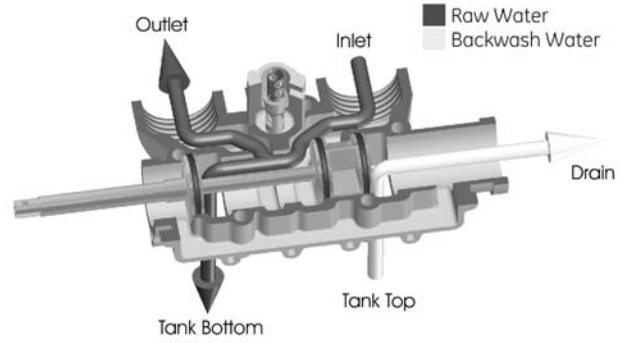

### 3 Brine and Slow Rinse

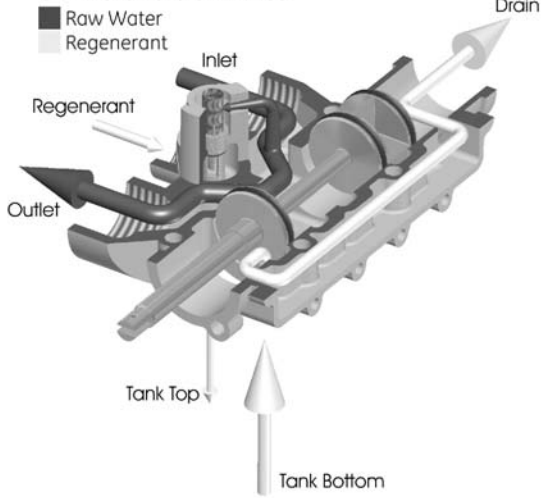

### 4 Fast Rinse and Refill

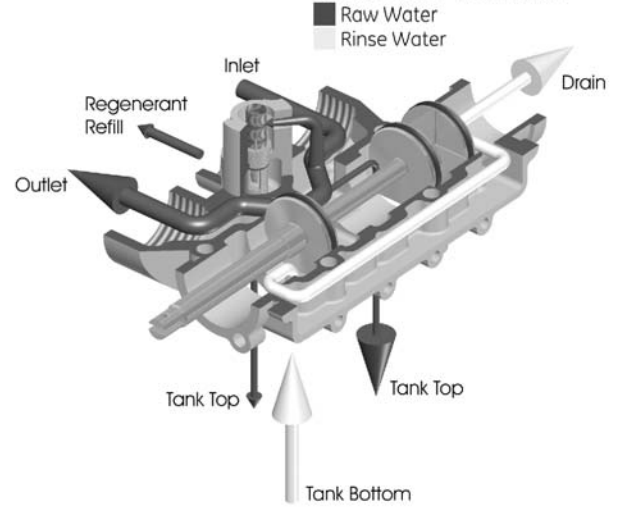

# 17.0 Performance

## 17.1 Pressure Drop vs. Flow

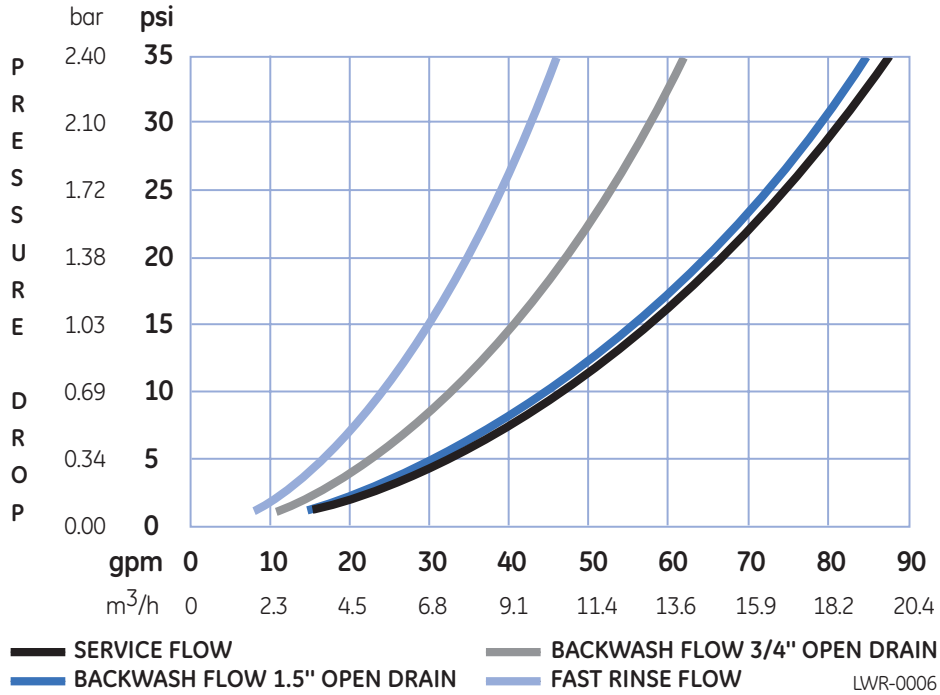

## 17.2 Injector Charts

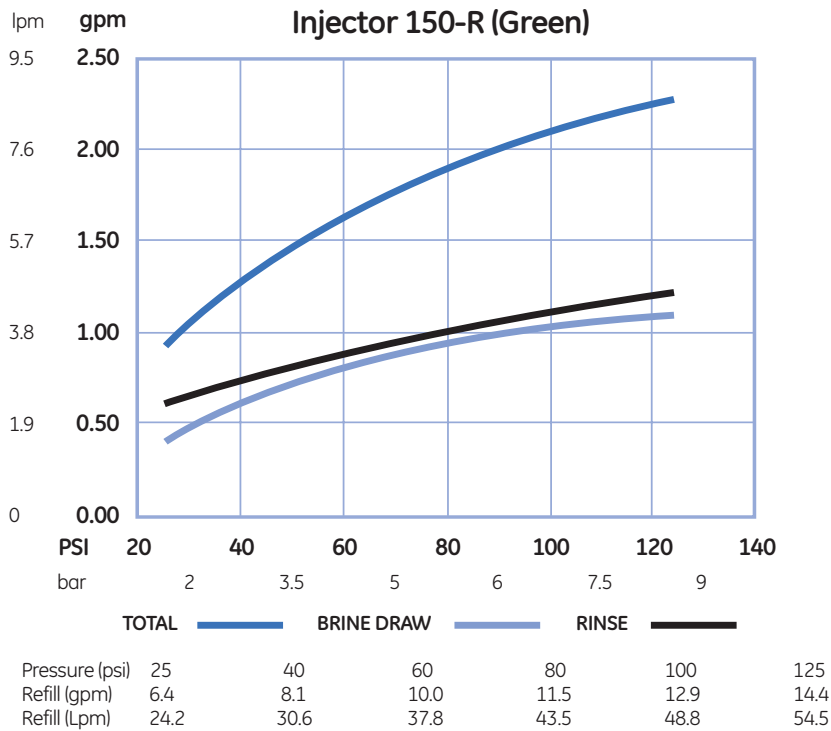

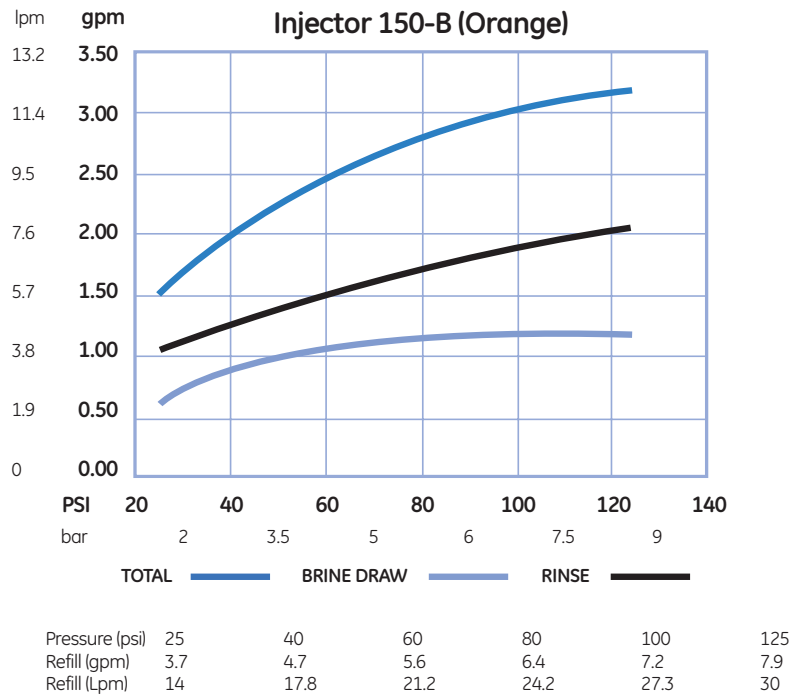
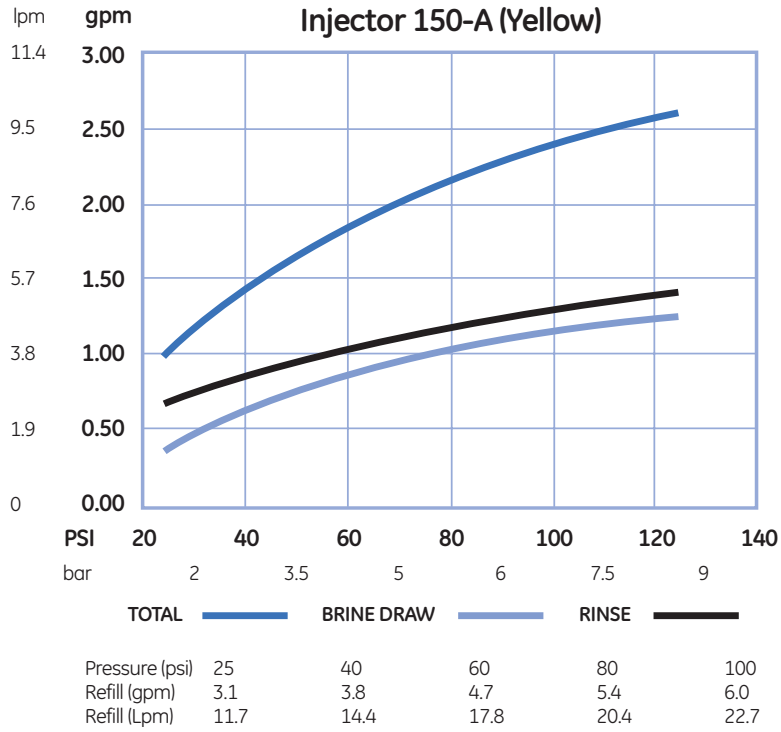

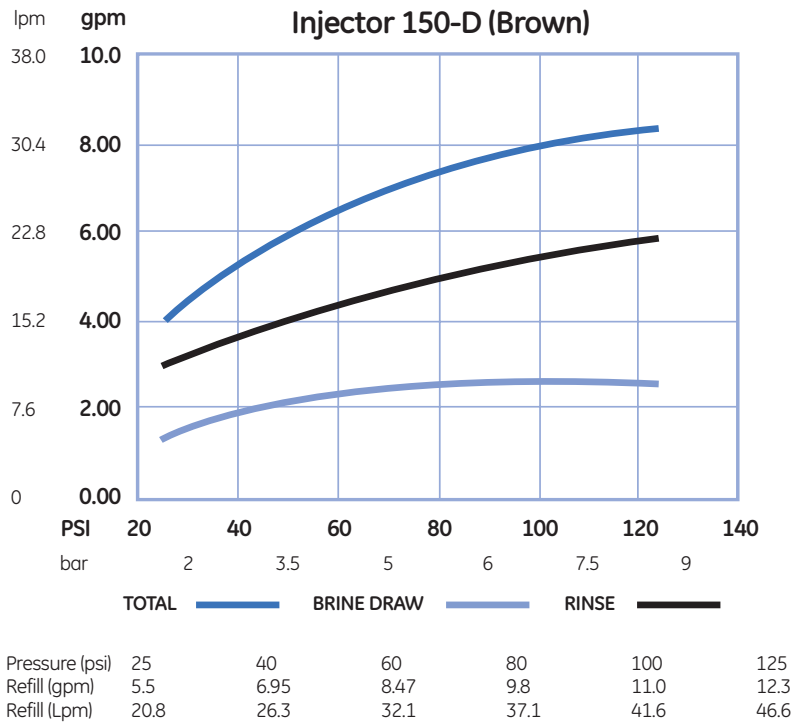
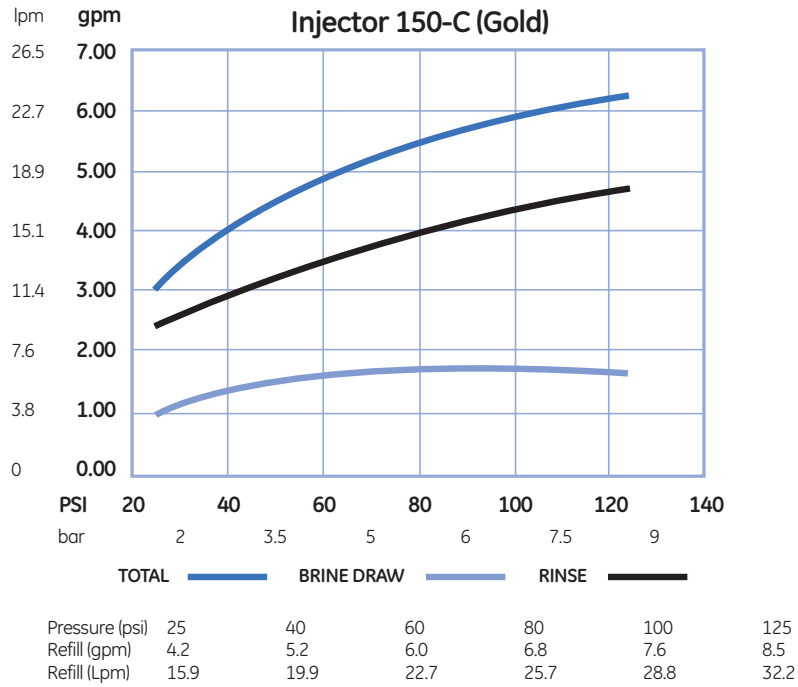

\*Brine draw and Rinse rates on empty tank.

---

---

### 17.3 Suggested Injector Backwash Sizing

Tank Diameter	Backwash Flow Control	Injector
14 in (36 cm)	5 gpm (19 Lpm)	150-R (Green)
16 in (41 cm)	7 gpm (26 Lpm)	150-A (Yellow)
18 in (46 cm)	9 gpm (34 Lpm)	150-B (Orange)
21 in (53 cm)	12 gpm (45 Lpm)	150-C (Gold)
24 in (61 cm)	15 gpm (56 Lpm)	150-C (Gold)
30 in (76 cm)	25 gpm (95 Lpm)	150-D (Brown)

**NOTE:** Suggested sizing intended for general guidance and must be adjusted based on specific application requirements. Contact resin manufacturer for recommended backwash and regenerant draw requirements.

# 18.0 Replacement Parts - Valve

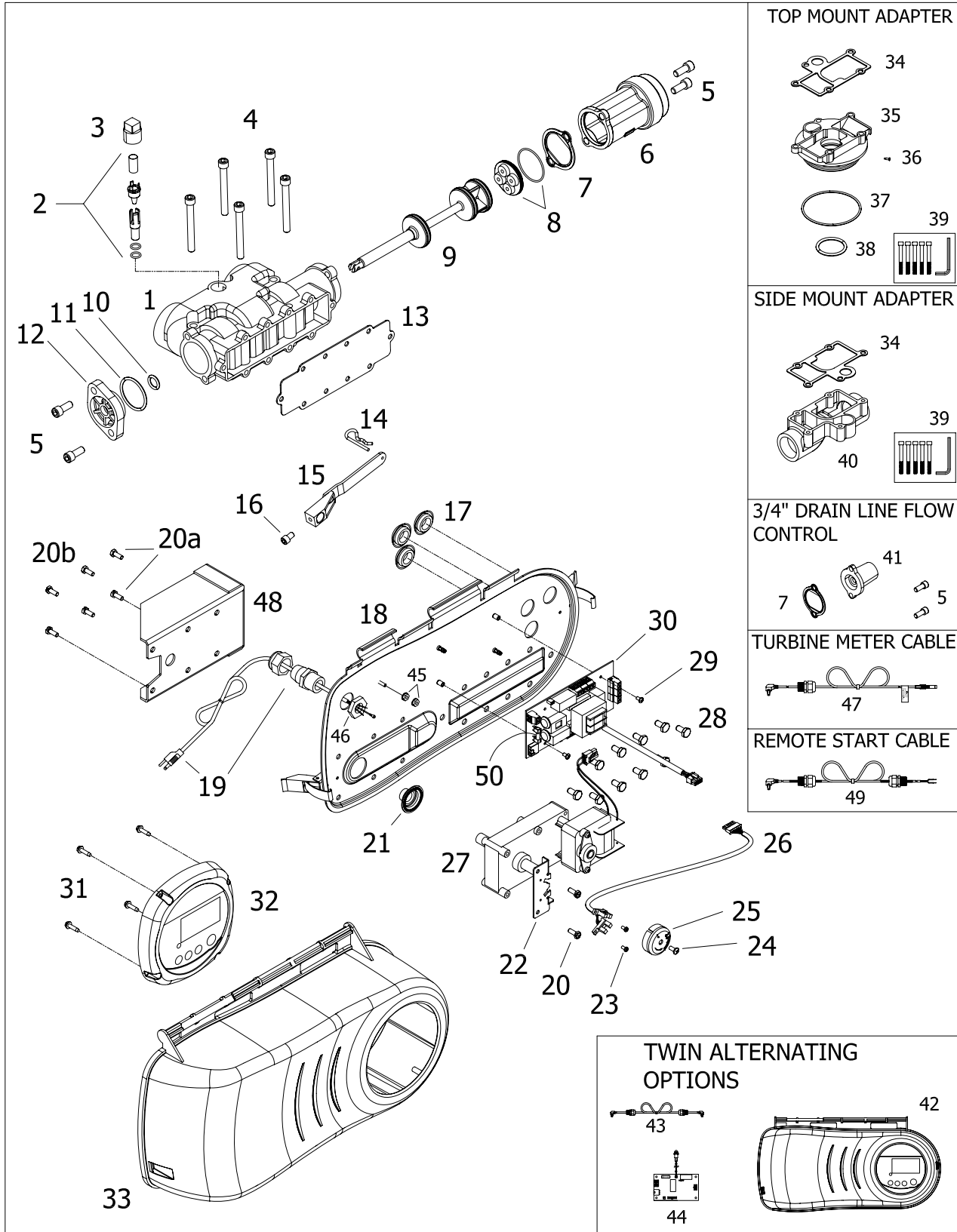

## Parts List

Ref. #	Part No.	Description	Ref. #	Part No.	Description
1		<b>Valve Body:</b>	25	1263670	Cam, Noryl, 4 Position (Included w/Item 27)
	1255724	NPT	26	1263687	Cable Assy. (Included w/Item 27)
	1243161	BSPT	27		<b>Drive Motor Assemblies:</b>
	1255728	NPT (Pressure Tap)		3025321	100/115 VAC Drive Motor Assembly
	1255727	BSPT (Pressure Tap)		3025322	200/230 VAC Drive Motor Assembly
2		<b>Injector Assembly:</b>	28	1005585	Screw, Hex Hd., 1/4-20 x 3/8 (10 reqd.)
	1034930	"R" (Green)	29	1072370	Screw, PH Pan Hd., #6-32 x 1/4 in. (2 reqd.)
	1034936	"A" (Yellow)			<b>Relay/Power Circuit Board Assemblies:</b>
	1034931	"B" (Orange)	30	3000602	Relay/Power Circuit Board, 115/230VAC (with 2 Auxiliary Relays)
	1034934	"C" (Gold)		3000603	Relay/Power Circuit Board, 100/200VAC (with 2 Auxiliary Relays, Japan)
	1234743	"D" (Brown)			
	1034170	Blank (undrilled)	31	1077781	Screw, #8 x 5/8, Hex Washer Hd, Self Tapping
	3017953	Injector Screen			
	1010301	Injector O-ring (2 Required)	32		<b>Logix Control Assembly:</b> (See Table 7 or 8)
3	1263693	Injector plug, 1/2 in. NPT	33	1263664	Cover, w/Gasket, Top Mount Adapter Kit
4	*	Cap Screw, 5/16-18 x 2-3/4 (5 reqd.) (Included in Item 39)	34	1264042	Gasket (Valve to Adapter) (Included w/ item 35 and 40)
5	1006266	Cap Screw, 5/16-18 x 3/4 (4 reqd.)	35	3019287	Adapter Kit, Top Mount, 316SS (Includes Items 36. 37. 38. 39)
6		<b>1-1/2 in. Open Drain Line Flow Control</b>	36	1078894	Screw Pack, #4-40, Thread Cutting (2 included in screw pack kit) (Included w/Item 35)
	1266062	Cap, Piston, 1.5 in NPT, 316SS	37	1079843	O-Ring (Included w/item 35)
	1266061	Cap, Piston, 1.5 in BSPT, 316SS	38	1079842	O-Ring (Included w/item 35)
7	1264065	Gasket, Drain Line Flow Control	39	1079077	Adapter Mounting Kit (Includes: 5 Mounting Screws & Allen Wrench)
8	3025323	Flow Control Holder Assy. w/ O-Ring	40	3019178	Side Mount Adapter Kit, NPT, 316SS (Includes Items 34, 39)
9	1263774	Piston		3019179	Side Mount Adapter kit, BSPT, 316SS (Includes Items 34, 39)
10	3015834	O-Ring	41		<b>3/4 in. Open Drain Line Flow Control</b>
11	1234965	O-Ring		1262519	Cap, Piston, .75 in. NPT
12	3006155	Cap		1262518	Cap, Piston, .75 in. BSPT
13	1264000	Gasket (Valve to Motor Plate)	42	1264594	Cover, TWIN, (No Logix)
14	1263694	Hitch Pin	43	1264581	Twin Interconnect Cable Assembly
15	3021612	Drive Link Assembly (Includes Item 16)	44	1264218	Twin Circuit Board
16	1006265	Screw, 1/4-20 x .38L (Included in Item 15)		1266071	Twin Circuit Board (Japan)
17	*	Knockout Seal, .875 in. (Heyco #3833) (3 reqd.)	45	3020800	Nut, Keps, 6-32, Stainless Steel (1 reqd.)
18	1264157	Motor Plate	46	1264578	Sealing Nut, Nylon, Black
19		<b>Power Cord Options:</b>	47	1263685	Turbine Meter Cable Kit
	1263689	North America	48	*	Fuse 5 A 250 V 5 mm x 20 mm
	1265917	Europe	49	1264597	Remote Regen Start Cable
	1265916	Australia			<b>.75 Backwash Assemblies:</b> (Includes Items 5, 7, & 41) See Table 5.
	1267871	Japan			<b>1.5 in. Backwash Assemblies:</b> (Includes Items 5, 6, 7, & 8) See Table 6.
	1265914	United Kingdom (Removable)			
20	1005850	Screw, Hex Hd., 10-24 x 1/2 (6 reqd.)			
20A	3020791	Screw, Hex Hd., 10-24 x 3/4 (2 reqd.)			
20B	3020790	Screw, Hex Hd., 10-24 x 5/8 (4 reqd.)			
21	1263683	Motor Shaft Boot Seal			
22	1263686	Bracket			
23	1072396	Screw, M3 x 0.5 x 6 (2 reqd.)			
24	1005662	Screw, PH Pan Hd., 8-32 x 3/8 in.			

\*Not sold as a spare part

**Table 5 .75-inch Drain Line Flow Controls.**

Part Number*	Flow Control Disk	
	gpm	m3/h
3019219	3 NPT	—
3019260	—	3 BSPT
3019250	4 NPT	—
3019261	—	4 BSPT
3019251	5 NPT	—
3019262	—	5 BSPT
3019252	6 NPT	—
3019264	—	6 BSPT
3019253	7 NPT	—
3019265	—	8 BSPT
3019233	9 NPT	—
3019266	—	9 BSPT
3019234	10 NPT	—
3019267	—	10 BSPT
3019235	12 NPT	—
3019268	—	12 BSPT
3019236	15 NPT	—
3019269	—	15 BSPT
3019237	25 NPT	—
3019270	—	25 BSPT
3019238	Open	—
3019271	—	Open

**Table 6 1.5-inch Drain Line Flow Controls.**

Part Number*	Flow Control Disk		Insert 1	Insert 2	Insert 3	Insert 4
	gpm	m3/h				
3019272	10 NPT	—	Black	Black	Blue	Blue
3019279	—	2.3 BSPT				
3019273	15 NPT	—				
3019280	—	3.4 BSPT	Orange	Blue	Orange	Orange
3001277	25 NPT	—				
3001465	—	5.6 BSPT				
3001278	30 NPT	—				
3001466	—	6.8 BSPT				
3001279	35 NPT	—				
3001467	—	7.9 BSPT	Orange	Orange	Orange	
3023816	40 NPT	—				
3023817	—	9.1 BSPT				
3001310	Open NPT	—				
3001468	—	Open BSPT				

\* Includes items 5, 6, 7 and 8.

Note: Install flow control holder assembly with flow washers facing the valve body.

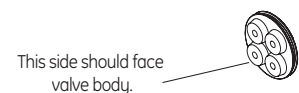

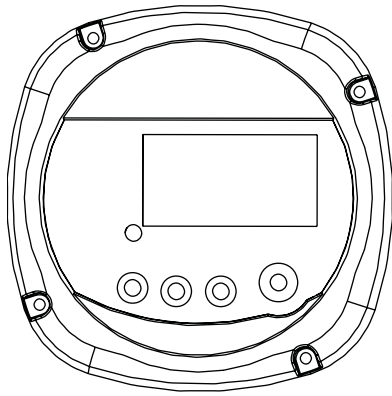

**150 Control**

**Table 7 742 Controller Options**

**Note:** All 742 models can initiate regeneration based on time clock or remote signal input.

North American Part Number*	World Part Number**	Model	Standard Application	Overlay Language
3019476	3019501	742	Conditioner	English
3019490	3019502	742F	Filter	English
3019491	3019503	742	Conditioner	Chinese
3019492	3019504	742F	Filter	Chinese
3019493	3019505	742	Conditioner	Japanese
3019494	3019506	742F	Filter	Japanese
3023813	3024072	742	Filter/Conditioner	No Overlay

\* North American Controllers for use with 115 VAC 60 Hz systems only.

\*\* World Controllers default to metric units on 50 Hz, or to U.S. units on 60 Hz.

**Table 8 762 Controller Options**

**Note:** All 762 models can initiate regeneration based on flow or time.

North American Part Number*	World Part Number**	Model	Standard Application	Overlay Language
3019495	3019507	762	Conditioner	English
3019496	3019508	762F	Filter	English
3019497	3019509	762	Conditioner	Chinese
3019498	3019510	746F	Filter	Chinese
3019499	3019511	762	Conditioner	Japanese
3019500	3019512	762F	Filter	Japanese
3023814	3024074	762	Filter/Conditioner	No Overlay

\* North American Controllers for use with 115 VAC 60 Hz systems only.

\*\* World Controllers default to metric units on 50 Hz, or to U.S. units on 60 Hz.

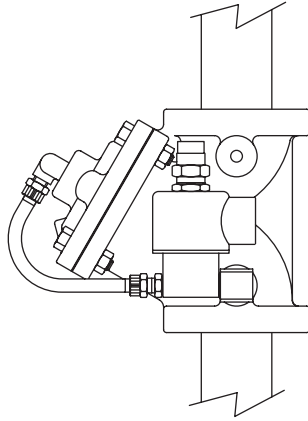

**Service Shut-off Kit**

**Table 9 Service Shut-off Kits**

<b>Part Number</b>	<b>Valve Model</b>	<b>Valve Material</b>	<b>Solenoid</b>	<b>Connections</b>
3019947	K52	Composite	120 V	1-1/2" male NPT
3019949	K52	Composite	220 V	1-1/2" female socket weld
3019956	V46	316 Stainless Steel	120 V	1-1/2" female NPT
3019957	V46	316 Stainless Steel	220 V	1-1/2" female BSPT







